



**TENDER FOR PROPOSED INTERIOR FURNISHING WORKS OF CIRCLE OFFICE, AT
2ND FLOOR V2 BUILDING, PROPERTY NO. 98/4, AIRPORT ROAD, HUBBALLI-
580030**

NOTICE TYPE : DOMESTIC TENDER NOTICE

AUTHORITY TYPE : PUBLIC SECTOR BANK

ISSUED BY

The Deputy General Manager
Premises & Estate Section
Canara Bank Circle Office
52A, Shanbhag Building, Unkal Cross,
Sai Nagar Road, Hubballi-580031
Tel: 0836-2278860.
e-mail: pecohub@canarabank.com;



CONTENTS	
Sl.No	DETAILS
TECHNICAL BID	
1.	Notice Inviting Tender
2.	General Rules and Directions to Tenderers
3.	Schedule's A to F
4.	Conditions of contract
5.	Clauses of contract
6.	Special conditions
7.	Technical specification for Furnishing works
8.	Safety code
9.	Model rules for protection of Health and sanitary arrangements for workers employed by contractors
10.	List of preferred makes
11.	Tender Form
12.	ANNEXURE - 1 - Bio Data of Tenderer
13.	ANNEXURE - 2 - Acceptance
14.	ANNEXURE - 3 - Form of Agreement
15.	ANNEXURE - 4 - Details of plants and equipment available for this work.
16.	ANNEXURE - 5 - List of relatives employed in Canara Bank
17.	ANNEXURE - 6 - Format for receipt of Materials at site
18.	ANNEXURE - 7 - Format of measurement book
19.	ANNEXURE - 8 - Format for running bill
20.	ANNEXURE - 9 - Format for Rate analysis
21.	ANNEXURE -10 - Format for certificate of payment
22.	ANNEXURE -11 - Format of site order book
23.	ANNEXURE -12 - Format for application - Extension of time
24.	ANNEXURE -13 - Format for Hindrance register
25.	ANNEXURE -14 - Format of BG for EMD
26.	ANNEXURE -15 - Format of BG for security deposit
27.	ANNEXURE -16 - List of Retired Government/Bank Employees
28.	ANNEXURE -17 - Draft agreement of integrity pact
29.	ANNEXURE- 18 - Base Price of materials
29.	ANNEXURE -19 - Indemnity format
30.	Tender drawings
FINANCIAL BID	
31.	Price Bid (Bill of quantities -BOQ) -

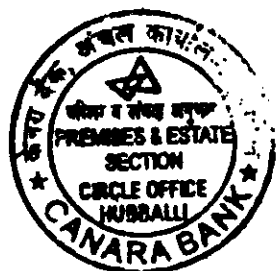

NOTICE INVITING TENDERS

Canara Bank, Premises & Estate Section, Circle Office, 52A, Shanbhag Building, Unkal Cross, Sai Nagar Road, Hubballi invites item rate sealed tenders from eligible & experienced Firms / Companies in "TWO BID CONCEPT" for the Interior furnishing works of Circle Office proposed at 2ND Floor V2 Building, Property No. 98/4, Airport Road, Hubballi-580030.

1) Details of the Tender:

Tender Ref.	CBCO:HUB:INT:1/20 dated 04.11.2020
Name of the Work	Interior furnishing works of Circle Office
Location of Work	2 nd Floor V2 Building, Property No. 98/4, Airport Road, Hubballi- 580030.
Estimated cost of the works	Rs.212.92 Lakhs (Approx)
Earnest Money deposit	Rs.4,24,000/- by way of Demand Draft of a Scheduled Bank drawn in favour of Canara Bank Circle Office, Hubballi payable at Hubballi.
Issue of tender document	04 th November -2020
Cost of tender application (inclusive of GST)	Rs 2,360/- by way of Demand Draft of a Scheduled Bank drawn in favour of Canara Bank Circle Office, Hubballi payable at Hubballi.
Last date of submission of pre-bid queries	17 th November - 2020 till 5.00pm
Pre-bid meeting	18 th November- 2020 at 3.00pm
Last date of submission of Tender	25 th November -2020 till 3.00pm
Opening of Technical bids	25 th November -2020 at 4.00 pm or as decided by the bank.
Opening of Financial bids	Date & time will be informed to the qualified bidders through e-mail/ letter.
Period of completion	60 days from the date of issue of work order
Tender documents (soft copy)	Can be downloaded from Canara Bank's web site https://canarabank.com/english/announcements/ & Central Public Procurement www.eprocure.gov.in from 04.11.2020 till last date of submission
Last date and time for submission of the tender	Sealed envelopes to be submitted on or before 25.11.2020 by 3.00PM to the office of: The Deputy General Manager, Canara Bank, Circle Office, Premises & Estate Section, 52A, Shanbhag Building, Unkal Cross, Sai Nagar Road, Hubballi-31

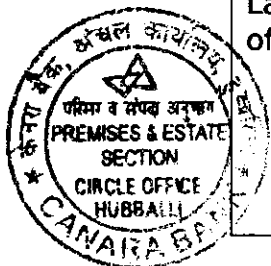

2) **Eligibility Criteria:** Bidders who fulfill the following requirements are eligible to apply. The tenderer should not have been blacklisted by any of the client/ organization like Government department / PSUs / PSBs /Autonomous institution and should submit a declaration on letter head confirming the same.

Sl.	Eligibility Criteria	Documents Required
1	The Tenderer should be registered with CPWD or State PWD or MES or Railways or such other Government organizations or Registered in Public sector units or Public sector Bank's or Financial Institutions or Reputed Corporate companies, MNC's, IT companies as a furnishing works contractor.	A copy of valid registration certificate from respective authorities. Works Completion / work order copies from the customer prior to 30.09.2020.
2	The Tenderer should have minimum of 05 (Five) years' experience in the relevant field as on 30.09.2020.	Copy of the registration of firm/ company/agency with competent authority
3	Bidder should have a minimum of Rs.64 Lakhs annual average turnover from furnishing works during last three financial years. If, Audited balance sheet is not available for 2019-20, Last 3 years FY may be taken as 2016-17,2017-18,2018-19	Audited balance sheet and P&L account for the years mentioned and certificate from the Chartered Accountant.
4	Tenderer should have executed any of the following work in a single contract during the last Seven (7) years ending with 30.09.2020 for at least, One (1)similar work costing Rs 171 LAKHS OR Two (2) similar works each costing Rs 107 LAKHS OR. Three (3) similar works each costing Rs 85 LAKHS Similar works means furnishing works including modular work stations, partitions, storage units, paneling, tables and false ceiling for offices / residential /banks buildings other than ready supply items.	Satisfactory work completion certificates from clients clearly indicating the cost and nature of works executed (Please refer to similar works).
5	The contractor must have valid GST registration, PAN number.	Copy of the GST registration certificate and copy of PAN card.

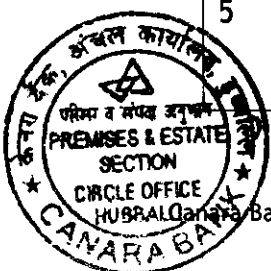

- 3) Tender documents can be downloaded only from the Banks & Central Public Procurement (CPP) portal www.eprocure.gov.in website free of cost. The Tender documents shall be in 12 size font & A-4 size paper and neatly bounded (hard bound / spiral bound) in two separate books (i.e. Technical bid and Financial bid) and submitted as detailed in clause 8 & 9 below.
- 4) Tender documents consists of Notice Inviting the Tender (NIT), Eligibility criteria, General rules and Directions to Tenderers, Schedules A to F, Conditions of contract, Clauses of Contract, Special conditions, Technical specifications, Safety code, Model rules for protection of Health & sanitary arrangements, List of preferred makes, Annexures 1 to 19, Schedule of Quantity(SOQ).
- 5) Tenders shall be on prescribed Form for item rate tenders as issued by the Bank / hosted by the Bank in website & Central Public Procurement (CPP) portal www.eprocure.gov.in
- 6) The site is ready for commencement of works.
- 7) Nature of the document: **TWO BID CONCEPT**. This Tender document comprises of the following:
 - A. **TECHNICAL BID: (first envelope)** consisting of following should be hardbound/spiral bound and submitted as in Sl. No. 8 & 9 below in a separate envelope-
 - a) EMD - Earnest Money Deposit
 - b) Notice inviting tender(NIT).
 - c) General Rules & directions to tenderer .
 - d) Schedules.
 - e) Conditions of contract.
 - f) Clauses of contract.
 - g) Special conditions
 - h) Safety code.
 - i) Model rules for protection of health and sanitary arrangements for workers employed by contractors.
 - j) Technical specifications for furnishing works.
 - k) Preferred makes/brand of materials
 - l) Annexures 1 to 19
 - m) Integrity pact.
 - n) Tender Drawings.

B. FINANCIAL BID (second envelope): Schedule of quantity (SOQ). Financial bid should be hardbound / spiral bound and submitted in separate envelop as in Sl. No. 8 & 9 below.

- 8) **Submission and opening of Tenders:**
 - a) Tenders on prescribed form should be placed in two envelopes one sealed envelope consisting of "Technical bid" duly super scribed as "Technical bid" and other sealed envelope consisting "Financial bid" duly superscribed as "Financial Bid" and both envelopes shall be kept in one bigger sealed single envelope, with the name of work, Name of Tenderer and due date written on the envelopes.
 - b) Sealed Tenders shall be addressed to The Deputy General Manager, Premises & Estate Section, Canara Bank, Circle office, 52A, Shanbhag Building, Unkal Cross, Sai Nagar Road, Hubballi-580031. Sealed Tenders shall be dropped in the TENDER BOX kept at the above said address.

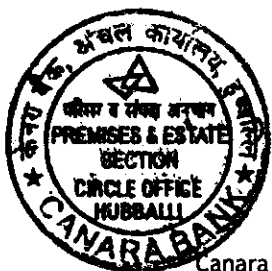

- c) If last day of submission of tender is declared a holiday under NI Act by the Government subsequent to issuance of tender the next working day will be deemed to be the last day for submission of the tender. The first part of tenders i.e. Technical bid will be opened on the same day and location of tender submission.
- d) Technical bids will be evaluated based on the Bank's eligibility criteria's. Wherever contractors / agencies are submitting consolidated completion certificates, then the Bank may request for supporting documents for split-up of works certified from the client / project architects as per the eligibility criteria's. Bank's decision in this regard is final and shall be binding on all.
- e) The Financial bid of only the technically qualified / shortlisted applicants will be opened on a pre-notified time & date, under intimation to such qualified / shortlisted applicants. Lowest quoted tender (L1) will be arrived based on the evaluation of all the financial bids and after mathematical scrutiny and freak rate analysis. Bank's reserves rights of accepting any and all the financial bids without assigning any reasons whatsoever.
- 9) The tender shall be accompanied by earnest money deposit of Rs.4,24,000 /- (Rupees Four Lakh Twenty Four thousand only) by way of Demand Draft of a Scheduled commercial Bank issued in favour of Canara Bank, Circle Office, Hubballi payable at Hubballi. EMD can also be submitted by way of irrevocable Bank guarantee from scheduled commercial Bank other than Canara Bank valid for 120 days with claim period of 60 days in the format prescribed by the Bank. EMD shall be submitted with the Technical bid only and should be kept along with cover containing the Technical bids.

Submission of EMD in the form of fixed deposit or in any other form is not acceptable and tenders with such EMD shall be rejected. No interest shall be allowed on the Earnest Money Deposit (EMD). Tenders without EMD shall be summarily rejected. However, MSEs are exempted from paying EMD as per MSME Act 2012. For getting the benefits in case of MSE firms, contractors / agencies should submit exemption certificate issued from the relevant authorities.

- 10) Copies of other drawings and documents pertaining to the works will be open for inspection by the tenderers at tender issuing Office of the Bank.
- 11) Tenderers are advised to inspect and examine the site and its surroundings and satisfy themselves before submitting their tenders, as to the means of access to the site, the accommodation they may require and in general shall themselves obtain all necessary information as to risks, contingencies and other circumstances which may influence or affect their tender. A tenderer shall be deemed to have full knowledge of the site whether he inspects it or not and no extra charges consequent on any misunderstanding or otherwise shall be allowed. Submission of a tender by a tenderers implies that he has read this notice and all other contract documents and has made himself aware of the scope and specifications of the work to be done, site details and local conditions and other factors bearing on the execution of the work.

The tenderer shall be responsible for arranging and maintaining at his own cost all

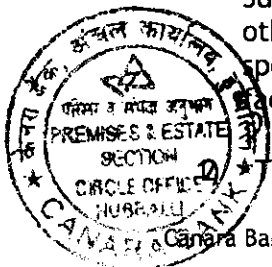

materials, labour, tools and plants, water, electricity, access, facilities for workers and all other services required for executing the work unless otherwise specifically provided for in the contract documents.

- 13) Canara Bank reserves to itself the right of accepting the whole or any part of the tender and the tenderer shall be bound to perform the same at the rate quoted.
- 14) The tender for the works shall remain open for acceptance for a period of 90 days from the date of opening of tenders. If any tenderer withdraws his tender before the said period or makes any modifications in the terms and conditions of the tender which are not acceptable to the Bank, then the Bank shall, without prejudice to any other right or remedy, be at liberty to forfeit full value of the earnest money as aforesaid.
- 15) This Notice Inviting Tender shall form a part of the contract document. The successful Tenderer/contractor, on acceptance of his tender by the Accepting Authority, shall, enter in to an agreement within 7 days from the date of acceptance letter.
- 16) Canara Bank does not bind itself to accept the lowest or any other tender, and reserves to itself the authority to reject any or all of the tenders received without the assignment of a reason. All tenders in which any of the prescribed conditions are not fulfilled or new conditions are stipulated by the tenderer or are incomplete in any respect are liable to be rejected.
- 17) Canvassing whether directly or indirectly, in connection with tenders is strictly prohibited and the tenders submitted by the Bidders who resort to canvassing will be liable to rejection.

18) Pre bid queries and clarification to Tender:

The tenderer should carefully examine and understand the specifications, terms and conditions of the Tender and may seek clarifications, if required. The tenderer in all such cases seek clarification in writing in a word document (.doc) in the same serial order of that of the Tender by mentioning the relevant page number and clause number of the Tender. The soft copy of the pre-bid queries should be sent by E-Mail to pecohub@canarabank.com and the pre-bid query should be in the following format.

Sl No	Page No	Tender Clause No	Tender Clause	Query

All communications regarding points requiring clarifications and any doubts shall be given in writing to the Deputy General Manager, Canara Bank, Circle office, 52A, Shanbhag Building, Unkal Cross, Sai Nagar Road, Hubballi 580031 by the intending tenderers before 5:00 PM on 17.11.2020. No oral or individual consultation shall be entertained. No queries will be entertained from the tenderers after the pre-bid meeting.

Pre-Bid meeting:

A pre-bid meeting of the intending tenderer will be held as scheduled below to clarify any point /doubt raised by them in respect of this Tender document:

Date	Time	Venue
18.11.2020	3.00 PM	Canara Bank, Circle office, 52A, Shanbhag Building, Unkal Cross, Sai Nagar Road, Hubballi-580031

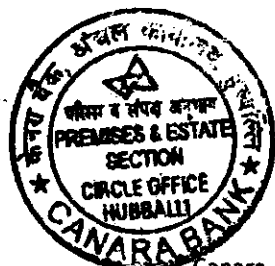

No separate communication will be sent for this meeting. If the meeting date is declared as a holiday under NI Act by the Government subsequent to issuance of RFP, the next working day will be deemed to be the pre-bid meeting day. Authorized representatives of interested tenderers shall be present during the scheduled time.

The Bank will consolidate all the queries and discussions during the pre-bid meeting and the consolidated replies for the queries shall be made available in the Bank's website and no individual correspondence shall be made. The replies/clarification of the Bank in response to the queries raised by the bidder/s, and any other clarification / amendments / corrigendum furnished hereof will become part and parcel of the Tender document and it will be binding on the tenderers.

Non-reply to the queries raised by any of the Tenderer shall not be accepted as a valid reason for non-submission of the Tender. In addition, non-reply to any query may not be deemed the version of the Tenderer as reflected in the query has been accepted by the Bank.

19) Amendment to Tender document:

At any time prior to deadline for submission of Tender, the Bank, for any reason, whether, at its own initiative or in response to a clarification requested by prospective bidder may modify the Tender document by amendment.

Notification of amendments will be made available on the Bank's website (www.canarabank.com) and will be binding on all tenderers and no separate communication will be issued in this regard.

In order to allow prospective tenderers reasonable time in which to take the amendment into account in preparing their tender, the Bank, at its discretion, may extend the deadline for a reasonable period as decided by the Bank for the submission of tender.

20. Brief details of the work:

The work involves interior furnishing works such as partitions, Modular work stations, paneling, storage units, false ceiling works full height cabins and cubicles, etc.

21. Definition: A "Tenderer / Bidder" is the Individual / Proprietor / Partnership Firm / Company who submits its tender for the subject works.

22. Running Bill payments:

Running bills shall be considered subject to a minimum bill value of Rs.40.00 lakhs (Rupees Forty lakhs). All the bills shall be prepared by the contractor in the form prescribed by the Employer/Bank. The bills in proper forms must be duly accompanied by detailed measurements, supporting documents (Invoices) for procuring the raw materials like plywood, laminate, hardware, etc as per the approved list of materials in support of the quantities of work done and must show deductions for all previous payments, retention money, etc if any.

The Bank's authorized official shall issue a certificate after due scrutiny of the contractor's bills, joint verification of the measurements and inspection of

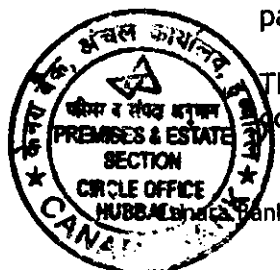

quality of works executed on site.

The amount stated in an running bill shall be the value of works properly executed on site as per Bank's specifications and payment will be allowed to the extent of works completed on site based on the Bank's discretion. If any works are partly completed then the proportionate payment will be released as per the actual after deducting the applicable taxes and retention money payments made earlier if any. Bank will not consider any payments on account of raw materials supplied at site (like supply of plywood, laminate, hardware, etc).

Bill payment will be made within the period of 15 (Fifteen) working days after submission of running bills along with the certificate issued by the Bank's authorized official.

All the interim payments shall be regarded as payments by way of advance against the final payment only, and not as payments for work actually done and completed, and shall not preclude the requiring of bad, unsound, and imperfect or unskilled work to be removed and taken away and reconstructed, or re-erected or be considered as an admission of the due performance of the contract, or any part thereof in any respect or the accruing of any claim, nor shall it conclude, determine or affect in anyway the power of the Employer/Bank under these conditions or any of them as to the final settlement and adjustment of the accounts or otherwise or in any other way vary or affect the contract.

23. FINAL PAYMENT:

The Final Bill shall be accompanied by a "Completion of Certificate" from the Bank official. Payments of final bill shall be made as per the procedure followed for running bills, after deduction of Retention Money as specified in relevant clauses which sum shall be refunded as stipulated in relevant clauses. Final bill should be submitted within 15 days of the final bill certification in proper bill format (Tax invoice). The acceptance of payment of the final bill by the contractor would indicate that he will have no further claim in respect of the work executed.

Final bill payment will be made within the period of 30 (Thirty) working days after submission.

For & on behalf of the Canara Bank

Date: 04.11.2020

Deputy General Manager
Circle office, 52A, Shanbhag Building, Unkal
Cross, Sai Nagar Road, Hubballi

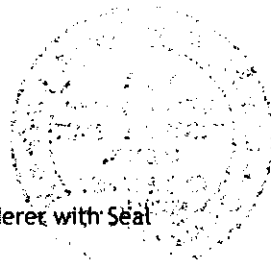
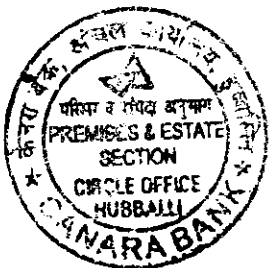

GENERAL RULES AND DIRECTIONS TO TENDERERS

1. All work proposed for execution by contract will be notified in a form of Invitation to Tender and signed by the Bank Officer inviting tender.

This form will state the work to be carried out, as well as the date for submitting and opening tenders and the time allowed for carrying out the work, also the amount of Earnest money to be deposited with the tender, and the amount of the security deposit to be deposited by the successful tenderers and the percentage, if any, to be deducted from bills. Copies of the specification, tender drawings and any other documents required in connection with the work signed for the purpose of identification by the officer inviting tender shall also be open for inspection by the contractor at the office of officer inviting tender during office hours.

2. In the event of the tender being submitted by a firm, it must be signed separately by each partner thereof or in the event of the absence of any partner, it must be signed on his behalf by a person holding a power-of-attorney authorizing him to do so, such power of attorney to be produced with the tender, and it must disclose that the firm is duly registered under the Indian Partnership Act 1952 by enclosing a copy of the partnership deed duly certified by one partner as true copy.

Tender by Hindu Joint Family (HUF) firm may be signed by the Kartha or Manager or any other duly authorized representative followed by the name and designation.

3. Receipts for payments made on account of a work, when executed by a firm, shall be in the name of the firm by one of the partners, or by some other person having due authority to give effectual receipts for the firm.
4. Any person who submits a tender shall fill up the printed prescribed form stating what rate he is willing to undertake each item of the work. Tenders, which propose any alteration in the work specified in the same form of invitation to tender, or in the time allowed for carrying out the work, or which contain any other conditions of any sort, will be liable to rejection. No single tender shall include more than one work. Tenders shall have the name and number of the works to which they refer, written on the envelopes. Modifications to specifications, item description, any clauses, conditions or any provisions whatsoever in the tender documents shall lead to disqualification of the tender.
5. In case the lowest tendered amount (worked out on the basis of quoted rate of Individual items) of two or more Tenderers is same, then such lowest Tenderers may be asked to submit sealed revised offer quoting rate of each item of the schedule of quantity for all sub-sections/sub heads as the case may be, but the revised quoted rate of each item of schedule of quantity for all sub sections/sub heads should not be higher than their respective original rate quoted already at the time of submission of tender. The lowest tender shall be decided on the basis of revised offer. If the revised tendered amount (worked out on the basis of quoted rate of individual items) of two or more Tenderers received in revised offer is

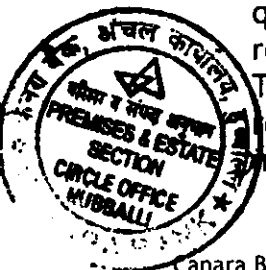

again found to be equal OR the tie is not resolved then the lowest tender, among such Tenderers, shall be decided based on the following criteria in the same order of preference:

1st preference - Total Value of the qualifying works - Eligibility criteria 4

2nd preference - Total turnover during last 3 financial years - Eligibility criteria 3

In case of any such lowest Tenderer in his revised offer quotes rate of any item more than their respective original rate quoted already at the time of submission of tender, then such revised offer shall be treated invalid. Such case of revised offer of the lowest Tenderer or case of refusal to submit revised offer by the lowest Tenderers (tied amount) shall be treated as withdrawal of his tender before acceptance and 50% of his earnest money shall be forfeited.

In case all the lowest Tenderers those have same tendered amount (as a result of their quoted rate of individual items), refuse to submit revised offers, then tenders are to be recalled after forfeiting 50% of EMD of each lowest Tenderers.

Tenderer whose earnest money is forfeited because of non-submission of revised offer, or quoting higher revised rate(s) of any item(s) than their respective original rate quoted already at the time of submission of his bid shall not be allowed to participate in the retendering process of the work.

6. The rate quoted shall comply to the following:

(a) The rate(s) and/or amount(s) must be quoted in decimal coinage. Amounts must be quoted in full rupees by ignoring fifty paise and less and considering more than fifty paise as rupee one.

(b) In case of illiterate contractors the rates or the amounts should be attested by a witness, with a declaration that the contents of the tender documents have been explained to the tenderer.

(c) The rate columns should be filled in English figures and English words.

(d) The rate and amount columns for alternative items, if any, shall be filled up but amounts shall not be added in the total. The amount of alternative items of which quantities are not mentioned shall not be filled.

7. In the case of any errors or omissions in the quoted rates, the rates given in the tender marked "Original" shall be taken as correct rates. All corrections such as cuttings, interpolations, omissions and over-writings shall be numbered as 'c', 'i', 'o' and 'ow' and initialed and total of such c, l, o and ow on each page certified at the end of the page with grand total at the end of the bill / schedule of quantities. Use of correcting fluid, anywhere in tender document is not permitted. Such tender is liable for rejection.

8. The officer inviting tender or his duly authorised assistant will open tenders in the presence of any intending contractors who may be present at the time, and will enter the amounts of the several tenders in a comparative statement in a suitable form. In the event of a tender being accepted for consideration, a receipt for the earnest money forwarded therewith shall thereupon be given to the Bidder who shall thereupon for the purpose of identification sign copies of the specifications and other documents



mentioned in Rule-I. In the event of a tender being disqualified and rejected, the earnest money forwarded with such unaccepted tender shall thereupon be returned to the contractor remitting the same, without any interest.

9. The Officer inviting tenders shall have the right of rejecting all or any of the tenders and will not be bound to accept the lowest or any one tender.
10. The Tenderer shall take all necessary precautions to ensure that all confidential information which the Tenderer obtains in the course of participating in this Tender or at any time thereafter is not disclosed or used other than for the purpose of project execution / scope of work / deliverables. Tenderer shall suitably defend, indemnify Bank for any loss / damage suffered by Bank on account of and to the extent of any disclosure of such confidential information. Confidential information for this purpose refers to such information pertaining to Bank provided to Tenderer which is marked as confidential and which is not available in the Public Domain".
11. In the case of item rate tenders, only rates quoted shall be considered. Any tender containing percentage below / above the rates quoted is liable to be rejected. Rates quoted by the contractor in item rate tender in figures and words shall be accurately filled in so that there is no discrepancy in the rates written in figures and words. However, if a discrepancy is found, the rates which correspond with the amount worked out by the contractor shall unless otherwise proved be taken as correct. If the amount of an item is not worked out by the contractor or it does not correspond with the rates written either in figures or in words then the rate quoted by the contractor in words shall be taken as correct. Where the rates quoted by the contractor in figures and in words tally but the amount is not worked out correctly, the rates quoted by the contractor will unless otherwise proved be taken as correct and not the amount. In event no rate has been quoted for any item(s), leaving space both in figure(s), word(s), and amount blank, it will be presumed that the contractor has included the cost of this/these item(s) in other items and rate for such item(s) will be considered as zero and work will be required to be executed accordingly.

In case the same item appears more than once in the schedule of work under the same sub head or among the different sub heads of works, the lowest rate quoted for that item shall be taken for other items also and tender will be evaluated accordingly.

12. The contractor whose tender is accepted shall be required to furnish by way of **Initial security** a sum which shall be equal to 2.0% (two percent) of the accepted value of the tender including the Earnest Money Deposit, within 14 (fourteen) days of the date of issue of the letter of acceptance of his tender. Demand Draft payable to the Canara Bank or by way of Fixed Deposit Receipt with the Canara Bank or by way of Bank Guarantee from any other Scheduled Bank other than Canara Bank in the prescribed format for the duration of the contract period and defect liability period. A further sum of 8% (eight percent) of the Gross value of each interim/final bill shall be deducted as retention money to make up, together with the Initial Security Deposit, a **total Security Deposit** equal to 10% on the first Rs. One lakh, 7.5 % on the next Rs. One Lakh and 5% of the remaining amount of the accepted value of the tender, subject to a maximum of

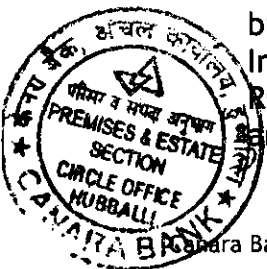

Rs.25 lakhs. The Initial Security amount will also be accepted in Fixed Deposit Receipt of Canara Bank for the full period of contract including defect liability period or in form of Bank Guarantee from any other Scheduled Bank in the prescribed format. In case a fixed deposit receipt of Canara Bank is furnished by the contractor to the Employer it shall be free from any loans or any encumbrance and shall be assigned / hypothecated to the Employer.

In case the successful tenderer fails to remit the Initial security deposit within the above stipulated time, the Earnest money deposit shall be forfeited.

13. In the case of any tender where unit rate of any item/items appears unrealistic, such tender will be considered as unbalanced and in case the tenderer is unable to provide satisfactory explanation such a tender is liable to be disqualified and rejected and / or the tenderer is liable for **additional security deposit** as demanded by the Employer in the form of Demand Draft or Bank guarantee from scheduled commercial Bank other than Canara Bank valid for contract period / smaller period (as decided by the Bank) in the format prescribed by the Bank.
14. On acceptance of the tender, the name of the accredited representative(s) of the contractor who would be responsible for taking instructions from the Employer and / or Engineer-in-charge shall be communicated in writing to Employer.
15. The rates quoted shall be all inclusive rates for the item of work described, including materials, labour, tools and plant, lead, lift carriage and transport supervision, Royalties, duties, levies, cess, entry tax, Octroi, profession tax, purchase tax, turnover tax, or any other tax on material in respect of this contract, overheads and profits, mobilizing, demolishing and other charges whatsoever including any special difficulties any restrictions for transport etc., complete for proper execution of the work as per drawings and specifications and no claim whatsoever for any extra payment shall be maintainable.

Any other Tax, any royalties, duties, levies, cess, Entry Tax, octroi, Profession Tax, Turnover Tax or any other Tax on material in respect of this contract shall be payable by the tenderer and the Bank will not entertain any claim whatsoever in respect of the same and nothing extra shall be paid / reimbursed for the same subsequently. The rates quoted shall include all the above. GST on works contract on finished works wherever applicable shall be paid by Bank as per extant rules. All charges payable to local bodies for any service connections for construction purposes, land tax, etc., shall also be paid by the contractor and nothing extra shall be paid/reimbursed for the same.

16. The contractor shall give a list of the Bank employees related to him with their places of posting and designations in prescribed Format as per the Annexure-05.

The tender for the work shall not be witnessed by a contractor or contractors who himself/themselves has/have tendered or who may and has/have tendered for the same work. Failure to observe this condition

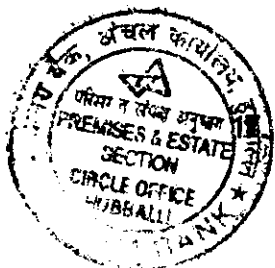

would render tenders of the contractors tendering, as well as witnessing the tender, liable to summary rejection.

18. Errors and omissions due to clerical, typographical or printing etc., if any, will have to be got clarified and corrected before quoting the rates. The interpretation given by the appropriate tender accepting authority of the Bank shall be final and binding.
19. Procurement of all materials, other than specifically stipulated to be issued by the Bank, if any, shall be at the cost and the responsibility of the contractor.
20. INTEGRITY PACT: Integrity Pact format is enclosed as Annexure - 17. The same to be duly filled in a non-judicial stamp paper of appropriate value and submitted along with offer. Name & details Independent External Monitor (IEM) identified for this Tender/RFP are as under:
 - a) Sri Rakesh Jain - rakeshjain18@hotmail.com
 - b) Sri D R S Chaudary - dilip.chaudhary@gmail.com

Only those tenderers, who commit themselves to the above pact with the Bank, shall be considered eligible for participate in the tendering process. Those bids/ tenders which are not containing the above pact are liable for rejection.

21. Tenderer shall fill in all the blanks and put their signature and seal on each page of the tender documents. The successful Tenderer will have to enter into an agreement with each component of the Tender document with the Bank.
22. The tender drawings under this NIT are only indicative to broadly understand the scope of the works. The contractor shall carry out the works according to the workings drawings/ construction drawings issued by the Engineer in charge during the course of work from time to time. Tenderer/ Contractor is not eligible for any claim on account of any differences between the tender drawings and working drawings.
23. If the tendered amount of L-1 is more than 20 % below from the estimated amount, he has to submit the bank guarantee of difference amount.
24. SOCIAL MEDIA POLICY:

No person of the bank or the contractors and third parties shall violate the social media policy of the bank. The following acts on the part of personnel of the bank or the contractors and third parties shall be construed as violation of social media policy:

 - a) Non-adherence to the standards/guidelines in relation to social media policy issued by the Bank from time to time.
 - b) Any omission or commission which exposes the Bank to actual or potential monetary loss or otherwise, reputation loss on account of non-adherence of social media related systems and procedures.

PURCHASE PREFERENCE:

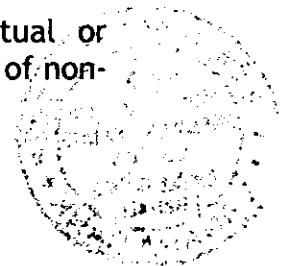
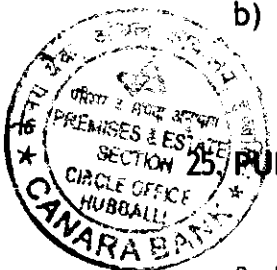

Purchase Preference to Micro and Small Enterprises (MSEs) and Startups and Purchase Preference linked with Local Content (PP-LC) shall be applicable subject to full compliance of other terms and conditions of the tender and Contract. Following are the conditions applicable as per the Government of India Guidelines on Purchase Preference.

1. Micro & Small Enterprises[MSEs]:

Procurement through MSEs (Micro & Small Enterprises) will be done as per the Policy guidelines issued by the Ministry of Micro, Small & Medium Enterprises vide Gazette notification no. D.L.-33004/99 dated 23.03.2012 and as amended from time to time. Following are the conditions applicable as per the Government of India Guidelines

- 1.1. MSEs should provide proof of their being registered as MSE (indicating the Terminal Validity Date of their Registration) for the item under Tender/ RFP along with their offer, with any agency mentioned in the Notification, including:
 - 1.1.1. District Industries Centres
 - 1.1.2. Khadi Village Industries Commissioner
 - 1.1.3. Khadi & Village Industries Board
 - 1.1.4. Coir Board or National Small Industries Corporation
 - 1.1.5. Directorate of Handicrafts & Handloom or Any other body specified by the Ministry of Micro, Small & Medium Enterprises.
 - 1.1.6. For ease of registration of Micro and Small Enterprises (MSMEs), Ministry of MSE has started Udyog Aadhaar Memorandum which is an online registration system (free of cost) w.e.f. 18th September, 2015 and all Micro & Small Enterprises (MSEs) who are having Udyog Aadhaar Memorandum should also be provided all the benefits available for MSEs under the Public Procurement Policy for Micro and Small Enterprises (MSEs), Order2012.
- 1.2. MSEs participating in tenders, quoting price within price band of L1+15% shall also be allowed to supply a portion of requirement by bringing down their price to L1 in a situation where L1 price is from someone other than MSE & such MSE shall be allowed to supply at least 20% of total tendered value. In case there are more than one MSEs within such price band and agree to bring down their price to L1, the 20% quantity is to be distributed proportionately among these Bidders.
- 1.3. MSEs are exempted from paying Application fee/cost & EMD, subject to furnishing of valid certificate for claiming Exemption.
- 1.4. The Eligible MSEs who intend to match the L1 Price (ultimately decided by the Bank) shall indicate the willingness to match the L1 Price within 6 working days from the date of communication from the Bank to avail the purchase preference.
- 1.5. Bidder has to submit as self-declaration accepting that if they are awarded the contract and they fail to sign the contract, or to submit a performance security before the deadline defined in the RFP, they will be suspended for the period of three years from being eligible to submit Bids for contracts with Canara Bank as per Form PP-B.
- 1.6. The aforesaid Policy is meant for procurement of only goods

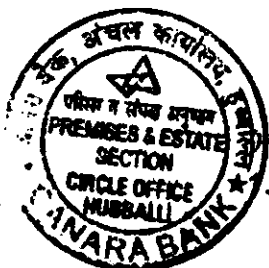

produced and Services rendered by MSEs and not for any trading activities by them. An MSE unit will not get any Purchase Preference over any other MSEUnit.

- 1.7. The details are available on web site dcmsme.gov.in. Interested vendors are requested to go through the same fordetails.

2. Startup:

- 2.1. Applicable for Indian Bidders only as defined in gazette notification no. D.L-33004/99 dated 11.04.2018 of Ministry of Commerce and Industry and as amended from time totime.
- 2.2. As mentioned in Section-II of O.M. No.F.20/2/2014-PPD(Pt.) dated 20.09.2016 of Procurement Policy Division, Department of Expenditure, Ministry of Finance on Prior turnover and prior experience, relaxations may be applicable for all Startups [whether Micro & Small Enterprises (MSEs) or otherwise] subject to meeting of the quality and technical specifications specified in tenderdocument.
- 2.3. Further, the Startups are also exempted from submission of Tender Fee andEMDs.
- 2.4. For availing the relaxations, bidder is required to submit requisite certificate towards Startup enterprise registration issued by Department of Industrial Policy and Promotion, Ministry of Commerce and the certificate should be certified by the Chartered Accountant (not being an employee or a Director or not having any interest in the bidder's company/firm) and notary public with legible stamp.
- 2.5. Bidder has to submit as self-declaration accepting that if they are awarded the contract and they fail to sign the contract, or to submit a performance security before the deadline defined in the RFP, they will be suspended for the period of three years from being eligible to submit Bids for contracts with Canara Bank as per FormPP-B.

3. Procurement through Local Suppliers (Make inIndia):

Department of Industrial Policy and Promotion under Ministry of Commerce and Industry vide letter no. P-45021/2/2017-PP (BE-II) dated 28.05.2018 has notified revised guidelines to be followed to promote manufacturing and production of goods and services in India under "Make in India"initiative.

- 3.1. "Local Supplier" means a supplier or service provider whose product or service offered for procurement meets the minimum local content as prescribed under the aforesaid order or by the competent Ministries/Departments in pursuance of the aforesaidorder.
- 3.2. The minimum local content shall be 50% in general (unless otherwise prescribed by the Nodal Ministry) and the margin of purchase preference shall be20%.
- 3.3. For award of contract, the following clauses shall be applicable in addition to other provisions in the bidding document in thisregard:
- 3.3.1. In procurement of goods, services or works in respect of which the Nodal Ministry has communicated that there is sufficient local capacity and local competition, and where the estimated value of procurement is Rs. 50 lakhs or less, only local suppliers shall be eligible. If the estimated value of procurement of goods

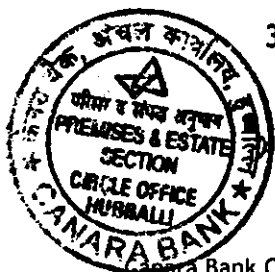

or services or works is more than Rs. 50 lakhs, the provisions of sub-paragraph 3.3.2 or 3.3.3, as the case may be, shall apply;

3.3.2. In the procurements of goods or works which are not covered by paragraph 3.3.1 and which are divisible in nature, the following procedure shall be followed:

3.3.2.1. Among all qualified bids, the lowest bid will be termed as L1. If L1 is from a local supplier, the contract for full quantity will be awarded to L1.

3.3.2.2. If L1 bid is not from a local supplier, 50% of the order quantity shall be awarded to L1. Thereafter, the lowest bidder among the local suppliers, will be invited to match the L1 price for the remaining 50% quantity subject to the local supplier's quoted price falling within the margin of purchase preference, and contract for that quantity shall be awarded to such local supplier subject to matching the L1 price. In case such lowest eligible local supplier fails to match the L1 price or accepts less than the offered quantity, the next higher local supplier within the margin of purchase preference shall be invited to match the L1 price for remaining quantity and soon, and contract shall be awarded accordingly. In case, some quantity is still left uncovered on local suppliers, then such balance quantity may also be ordered on the L1 bidder.

3.3.3. In procurement of goods or works not covered by sub-paragraph 3.3.1 and which are not divisible, and in procurement of services where the bid is evaluated on price alone, the following procedure shall be followed:

3.3.3.1. Among all qualified bids, the lowest bid will be termed as L1. If L1 is from a local supplier, the contract will be awarded to L1.

3.3.3.2. If L1 bid is not from a local supplier, the lowest bidder among the local suppliers, will be invited to match L1 price subject to local supplier's quoted price falling within the margin of purchase preference, and the contract shall be awarded to such local supplier subject to matching L1 price.

3.3.3.3. In case such lowest eligible local supplier fails to match the L1 price, the local supplier with the next higher bid within the margin of purchase preference shall be invited to match the L1 price and so on and contract shall be awarded accordingly. In case none of the local suppliers within the margin of purchase preference matches the L1 price, then the contract may be awarded to the L1 bidder.

3.4. Purchase preference for domestic manufacturer/local supplier, methodology of its implementation, value addition to be achieved by domestic manufacturers, self-certification, compliance, monitoring and other terms & conditions shall be as per the aforesaid Guidelines/Notifications. The Guidelines may be treated as an integral

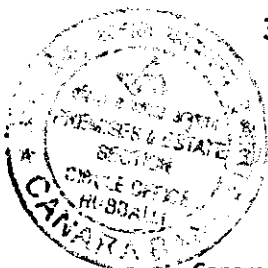

part of the tender documents.

- 3.5. The preference to 'Public Procurement (Preference to Make in India) Order 2017' shall be subject to meeting technical specifications and full compliance of other terms and conditions of the RFP and Contract.
- 3.6. The Bidder quoting value upto Rs. 10 Crores shall be required to provide self-certification (as per Form PP-C) along with the bid that the item offered meets the minimum local content in terms of para 9(a) of the Public Procurement (Preference to Make in India) Order 2017. Bidder shall also submit the list of items / services to be procured from Indian manufacturers / service providers. Bidder has to provide the value & percentage of the local content in price bids.
- 3.7. If Bidder is quoting more than Rs. 10 Crores in their Commercial Proposal, then Bidder has to submit a certificate (as per Form PP-D) from statutory auditor of the company (in case bidder is a company) or from a practicing Cost Accountant or practicing Chartered Accountant (in case bidder is not a company) along with his bid in terms of para 9(a) of the Public Procurement (Preference to Make in India) Order 2017. Bidder has to provide the value & percentage of the local content in price bids.
- 3.8. False declarations will be in breach of the Code of Integrity under Rule 175(1)(i)(h) of the General Financial Rules issued by the Ministry of Finance for which a bidder or its successors can be debarred for up to two years as per Rule (iii) of the General Financial Rules along with such other actions as may be permissible under law.
- 3.9. All the relevant documents/information regarding claim for preferential treatment under this policy must be submitted along with offer by the tenderers. Post tender submission of these information/documents shall not be considered. Further firms seeking these considerations shall be completely responsible for the truthfulness and authenticity of their claim for these benefits.
- 3.10. **Ministry of Electronics and Information Technology(MeitY):**
In furtherance of the Public Procurement (Preference to Make in India) Order 2017 notified vide reference cited above, Ministry of Electronics and Information Technology, Government of India has notified ten (10) electronic products vide reference F.No.33(1)/2017-IPHW dated 14.09.2017.
 - 3.10.1. Domestic Manufacturers are required to indicate the domestic value addition/Local Content in terms of Bill of Material (BoM) for the quoted products, in terms of aforesaid guidelines, in their bid. Bidders, claiming to bid in the status of domestic manufacturer/local supplier on behalf of domestic manufacturer are also required to give an undertaking in the format as given in MeitYForm-1.

3.11. **Department of Telecommunications(DoT):**

In furtherance of the Public Procurement (Preference to Make in India) Order 2017, Department of Telecommunications, Ministry of Communications, Government of India has notified Thirty-Six (36)

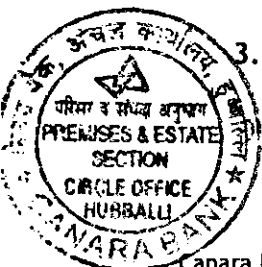

Telecom Products, Services and Works vide reference No. 18-10/2017-IP dated 29.08.2018.

3.11.1. Domestic Manufacturers are required to indicate the domestic value addition/Local Content in terms of Bill of Material (BoM) for the quoted products, in terms of aforesaid guidelines, in their bid. Bidders, claiming to bid in the status of domestic manufacturer/local supplier on behalf of domestic manufacturer are also required to give an undertaking in the format as given in DoTForm-1.

3.12. Canara Bank shall also have the authority to audit as well as witness production processes to certify the achievement of the requisite local content and/or to obtain complete back up calculation.

4. In case a bidder is eligible to seek benefit under Purchase PP-LC policy as well as PPP for MSE 2012, then the bidder should categorically seek benefits against only one of the two policies i.e. either PP-LC and MSE policy in Form PP-A. The option once exercised cannot be modified subsequently.

5. Purchase preference benefits shall be extended to the bidder based on the declared option subject to the bidder meeting the requirements contained in that purchase preference policy.

6. In case a MSEs bidder opts for purchase preference based on PP-LC, he shall not be entitled to claim purchase preference benefit available to MSE Bidders under PPP-2012. However, the exemptions from furnishing Bidding Document fee and Bid security/EMD shall continue to be available to MSE Bidders

7. For price matching opportunities and distribution of quantities among bidders (bidder's option to avail any one out of two applicable purchase preference policies, i.e., PP-LC-2017 or PPP-2012 will be considered), the precedence shall be in the following order:

7.1 Public Procurement Policy for MSE2012

7.2 Purchase Preference linked with Local Content (PP-LC).

◆ ◆ ◆ ◆ ◆ ◆ ◆

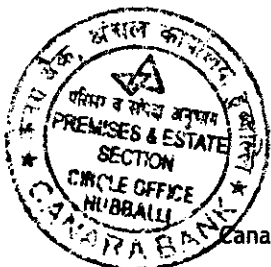

:: SCHEDULE s ::

SCHEDULE `A`::

Schedule of Quantities - SOQ - (Specified in detail and attached)
(Should be submitted in a separate envelope as financial bid)

SCHEDULE `B`::

Schedule of materials to be issued to the Bidder.

Sl. No	Description of items	Quantity	Rates in figures & words @which the materials will be charged to the Bidder	Place of Delivery
--------	----------------------	----------	---	-------------------

----- NIL -----

SCHEDULE - 'C'::

Tools and Plants to be hired to the Bidder under headings.

Sl. No	Description	Hire Charges per day
--------	-------------	----------------------

----- NIL -----

SCHEDULE 'D' ::

Extra schedule for work :

- i. Conditions of contract
- ii. Clauses of contract
- iii. Special conditions
- iv. Technical specifications for Furnishing works
- v. Safety code
- vi. Model rules for protection of Health & sanitary
- vii. List of preferred makes

SCHEDULE `E` ::

Name of work:: Interior Furnishing Works Of Circle Office, At 2nd Floor V2 Building, Property No.98/4, Airport Road, Hubballi-580030.

SCHEDULE `F` ::

Reference to Conditions of contract.

Definitions::

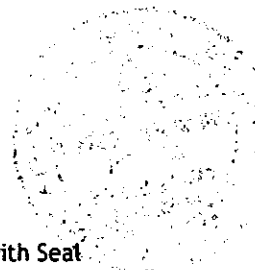
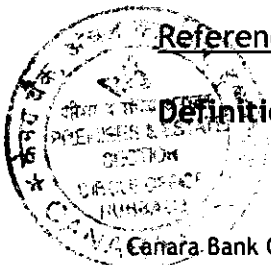

- 2(a)Work :: Interior Furnishing Works
- 2(b) Site :: 2nd FLOOR V2 BUILDING, PROPERTY NO.98/4, AIRPORT ROAD, HUBBALLI-580030
- 2(c) Bidder :: Successful tenderer to whom the work is awarded
- 2(d) Bank or Employer or Buyer :: Canara Bank
- 2(e) Engineer-in-Charge/Architect :: Bank's Engineers/Architect
- 2(f) Accepting Authority :: The Deputy General Manager
Canara Bank
Circle Office, 52A, Shanbhag building,
Unkal Cross, Sai Nagar Road,
Hubballi-580031.
- 2(g) Percentage on cost of materials : 15 % (fifteen %)
and labour to cover all over heads
and profits.
- 2(h) Standard Schedule of Rates :: Local Market
- Rates 2(i) Standard specification to be followed :: Specifications
- 2(j) Standard Contract Form :: Item rate Tender form of Canara Bank as modified & Corrected up to date of tender.

Reference to CLAUSES OF CONTRACT

Clause 1 :

Estimated cost of work: Rs.212.92 Lakhs

Earnest Money Deposit: Rs.4.24 Lakhs

Security Deposit : As below

- a) Retention money (Rule 13 of General Rules and Directions) :: 8% of the work executed deducted from bills Maximum of Rs. 25 lacs.
- b) Maximum percentage for quantity of items of work to be executed beyond which rates are to be determined in accordance with clause 12.2 & 12.3 :: Same as given below against clause 12 & its subclasses

Clause 2 ::	Authority for fixing compensation under clause 2.	General Manager, Circle Office Hubballi
-------------	---	--

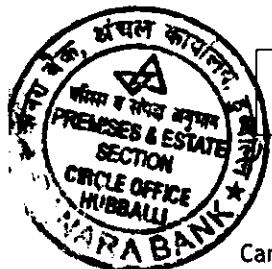

Clause 5	Time allowed for execution of work from date of commencement	60 days
Clause 5.4	Authority to give fair and reasonable extension of time for completion of work	General Manager, Circle Office Hubballi
Clause 10 B	Mobilization Advance Max. percentage of accepted tendered cost (contract amount)	-- NIL --
	Plant & Machinery Advance Maximum percentage of contract amount.	-- NIL --
	Rate of interest percent per annum on mobilization Advance and Plant and machinery Advance	-- NA --
	Other items (Specify) if any	-- NIL -
Clause 10 C ::	Escalation	-- NIL -
Clause 12 :: 12.1 (iii)	Schedule of Rates for determining. Rates for additional, altered or substituted items that cannot be determined under 12.1 (b) (i) & (ii)	CPWD Schedule of Rates 2018 & Local market Rates
12.1(vi)A(a)	Limit for value of any contract item, substituted item or contract-cum-substituted item beyond which sub-clauses (i) to (v) shall not apply and clauses 12.2 & 12.3 shall apply.	25 % (Twenty five %)
12.1(B)(vi)A(b)	(for lump sum contracts) Limit for deviations ordered on any individual trade beyond which provisions of sub-clauses (i) to (v) shall not apply and clauses 12.2 and 12.3 shall apply.	Not applicable.
12.1(vi)B(a)	Limit for value of any item of any individual trade beyond which sub-clauses (i) to (v) shall not apply and clauses 12.2 and 12.3 shall apply.	10 % (ten %)
Clause 15:: (b)(II)	Percentage payable to cover contractor's indirect expenses for suspension of work exceeding 30 days and not exceeding 3 months.	NIL
(c)	Percentage payable to cover contractor's indirect expenses for suspension exceeding 3 months.	NIL
Clause 16 ::	Competent Authority for deciding reduced rates.	Deputy General Manager, Circle Office, Hubballi
Clause 19 ::	Submission of Labour License	Within 14 days from the date of receipt of



		Acceptance letter
Clause 25	i) Amount of claim by any party beyond which Arbitrator shall give reasons for award.	All Claims
	ii) Accepting Authority	Deputy General Manager, Circle Office, Hubballi
Clause 36 (i)	a) Minimum Qualifications & experience required for Principal Technical Representative to be in- charge of work	GRADUATE ENGINEER with 3 years' Experience OR Diploma holder with 5 years OR Retired A. E. from Govt. Department with 5 years' experience as A.E
	b) Discipline to which the Principal Technical representative should belong	Electrical
	c) Minimum experience of works	3 years for Graduates and 5 years for Diploma.
	d) Recovery to be effected from the contractor in the event of not fulfilling provision of clause 36(i).	Rs. 30,000/-p.m.
Clause 42 :: (i) (a)	Schedule / Statement for determining theoretical quantity of cement and bitumen.	N.A
(ii).	Variations permissible on theoretical quantities ::	
	a) Cement -For works with estimated cost put to tender more than Rs. 5 lakhs	NIL
	b) Steel :: Reinforcement and structural steel sections for each diameter section and category	NIL
	c) All other materials	NIL

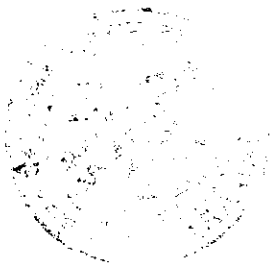

CONDITIONS OF CONTRACT

Definitions:-

1. The 'Contract' means the tender documents and acceptance thereof and the agreement duly executed between the Canara Bank and the Contractor, together with the documents referred to therein including these conditions, NIT, specifications, schedule of quantities, agreement, designs, drawings and instructions issued from time to time by the Employer and / or Engineer-in- Charge and all these documents taken together, shall be deemed to form one contract and shall be complementary to one another.

2. In the contract, the following expressions shall, unless the context otherwise requires, have the meanings, hereby respectively assigned to them.

a) The expression 'works' or 'work' shall be as mentioned Schedule F, unless there be something either in the subject or context repugnant to such construction be construed and taken to mean the works by or by virtue of the contract contracted to be executed whether temporary or permanent, and whether original, altered, substituted or additional.

b) The 'Site' shall mean the land/or other places on as mentioned Schedule F, into or through which work is to be executed under the contract or any adjacent land, path or street through which work is to be executed under the contract or any adjacent land, path or street which may be allotted or used for the purpose of carrying out the contract.

c) The 'Contractor' shall mean as mentioned in schedule F, the individual Kartha, or Manager of HUF, firm or Company, whether incorporated or not, undertaking the works and shall include the legal heirs/representatives of such individual or the partners composing firm and theirs legal heirs and successors, or company's authorized and constituted attorneys/agents and permitted assigns of such firm or company.

d) The 'Employer/Canara Bank means as mentioned in schedule F any officer of the Bank, who is specifically authorised to enter into contracts and incharge of the work mentioned in Schedule F.

e) The 'Engineer-in-Charge' means the Officer, Engineer and/or Site Engineer as mentioned in Schedule 'F' hereunder who shall supervise and be incharge of the work or any other person specifically deputed by the Employer.

f) 'Contract Price' shall mean the final accepted rates in the Schedule Ahereto.

g) 'Date of Contract' means the 'Calendar date on which the Employer and Contractor have signed the Agreement on the StampPaper.

h) "Accepting Authority" shall mean the authority mentioned in Schedule 'F'.

i) "Excepted Risk" are risks due to riots (other than those on account of contractor's employees or agents or persons worked under or at the instance of the contractor) or commotion (in so far as both these are uninsurable), war (Whether declared or not), invasion, act of foreign enemies, hostilities, civil war, rebellion revolution, insurrection, military or usurped power, any acts of Government, damages from fire, acts of God, such as earthquake, lightening and unprecedented floods,

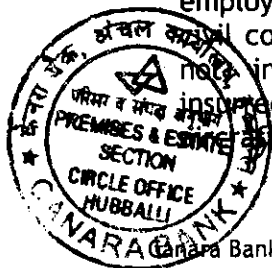

Tsunami and other causes over which the contractor has no control and accepted as such by the Accepting Authority.

j) "Market Rate" shall be the rate as decided by the Employer on the basis of the cost of materials and labour and the site where the work is to be executed plus the percentage mentioned in Schedule 'F' to cover all overheads and profits.

k) "Schedule(s)" referred to in these conditions shall mean the relevant schedule(s) annexed to the tender papers or the standard Schedule of Rates of the C.P.W.D. or state P.W.D. mentioned, if any, in Schedule 'F' hereunder, with the amendments thereto issued upto the date of receipt of the tender.

l) 'Approved' or 'Approval' wherever used in the specifications or schedule of Quantities shall mean, respectively, 'approved by or approval of the 'Accepting Authority' in writing.

m) 'Notice in writing' or 'written notice' shall mean a notice in writing typed or printed characters delivered to or sent by registered post to the last known address private or business address or registered office address, and shall be deemed to have been received when in ordinary course of post it would have been delivered, and/or delivered personally, or otherwise proved to have been received.

n) 'virtual completion' shall mean that the work / building is complete in all respects in the opinion of the Employer/Bank

o) 'Drawings' shall mean all drawings and / or sketches duly signed by the Engineer-in-charge or their representative on behalf of the Employer before commencement or during the progress of the work.

p) 'Letter of Acceptance' shall mean intimation by a letter issued by the Accepting Authority of the Employer / Bank to tenderers that his tender has been accepted in accordance with the provisions in the said letter.

q) Base price shall be as specified in Schedule F based on the actual price quoted by the authorized stockiest / wholesalers / showroom including GST, octroi and all other duties levied by the statutory / local authority and also excluding loading, unloading and carriage / transportation cost to the site of work, overheads, storage charges at site.

r) "Defect Liability Period" shall mean a period of twelve months from the certified date of virtual completion issued by the Engineer in charge / Employer. However, in the case of specialist contracts like for anti-termite treatment, water proofing treatment and the like the period of warranty in such contracts shall supersede the defect liability period, and the defect liability period of twelve months shall stand extended to be equal to the warranty period.

s) "Approved make" means materials as specified under List of preferred makes and also as approved by the Bank.

3. Scope and Performance:: Where the context so requires, words imparting the singular only also include the plural and vice versa. Any reference to masculine gender shall whenever required include feminine gender and vice versa.

4. Headings to these Conditions of Contract, Clauses of contract, special conditions, Technical specifications shall not be deemed to form part thereof or be taken into consideration in the inter-pretation or construction thereof or of the contract.

5. The contractor shall be furnished, free of cost one certified copy of the contract



documents (except standard specifications, Schedule of Rates) together with all drawings as may be forming part of the tender papers. None of these documents shall be used by the Contractor for any purpose other than for this contract.

6. Works to be carried out :: The work to be carried out under the contract shall, except as otherwise provided in these conditions, include all labour, materials, tools, plants, equipment and transport which may be required in preparation of and for and in the full and entire execution and completion of the works. The descriptions given in the Schedule of Quantities (Schedule - A) shall, unless otherwise stated, be held to include waste on material carriage and cartage, lead, lift, safety works, carrying and return of empties, hoisting, setting, fitting and fixing in position and all other labour necessary and for the full and entire execution and completion as aforesaid in accordance with good practice and recognized principles.

7. Rates

The rates quoted shall be all inclusive rates for the item of work described, including materials, labour, tools and plant, lead, lift carriage and transport supervision, Royalties, duties, levies, cess, entry tax, Octroi, profession tax, Sales Tax, VAT, purchase tax, turnover tax, GST or any other tax on material in respect of this contract, overheads and profits, mobilizing, demolishing and other charges whatsoever including any special difficulties any restrictions for transport, any other incidentals works etc. complete and for proper execution of the work as per drawings and specifications and no claim whatsoever for any extra payment shall be maintainable unless otherwise specifically exempted and are specified as payable or reimbursable under this Agreement.

8. Sufficiency of Tender::

THE Contractor shall be deemed to have satisfied himself before tendering as to the correctness and sufficiency of his tender for the works and of the rates and prices quoted in the Schedule of Quantities, which rates and prices shall, except as otherwise provided, cover all his obligations under the Contract and all matters and things necessary for the proper completion and maintenance of the works.

9. Discrepancies and Adjustment of Errors::

THE several documents forming the Contract are to be taken as mutually explanatory of one another, detailed drawing being followed in preference to small scale drawing and figured dimensions in preference to scale and special conditions in preference to General Conditions.

9.1 If there is any difference or discrepancy between the description of items as given in the schedule of quantities, particular specifications for individual items of work (including special conditions) and I.S. Codes etc., the following order of preference shall be observed:

- a) Description of the Item as detailed in Schedule of Quantities(SOQ).
- b) Particular Specifications, Special condition, Additional conditions if any
- c) Detailed Drawings
- d) CPWD specifications
- e) Clauses of contract
- f) Indian Standard Specifications of B.I.S.
- g) Manufacturer's specifications
- h) As decided by Employer

over, the Contractor is not allowed to take benefit out of any clerical /

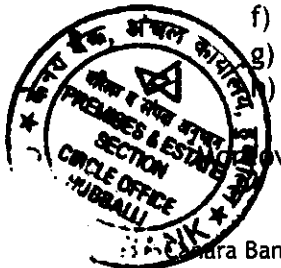

grammatical mistake in the standard clauses/ Bill of Quantities/Specifications etc. being used in the agreement”.

9.2 If there are varying or conflicting provisions made in any one or more document(s) forming part of the contract, the Accepting Authority shall be the deciding authority with regard to the intention of the document and his decision shall be final and binding on contractor.

9.3 Any error in description or quantity or rate in Schedule of Quantities or any omission therefrom shall not vitiate the Contract or release the Contractor from the execution of the whole or any part of the works comprised therein according to drawings and specifications or from any of his obligations under the Contract.

10. Signing of Contract :: THE successful tenderer/contractor, on acceptance of his tender by the Accepting Authority, shall, within 7 days from the stipulated date of start of the work sign the contract consisting of following failing which the Earnest money deposit shall be forfeited:-

- a) Standard form of agreement on stamp paper, the notice inviting tender, all the documents including drawings, if any, forming the tender as issued at the time of invitation of tender and acceptance thereof together with any correspondence leading thereto.
- b) Standard Contract Form as mentioned in Schedule 'F' consisting of:
 - a. Notice inviting tender(NIT).
 - b. General Rules & directions to contractor.
 - c. Schedules A to F.
 - d. Conditions of contract.
 - e. Clauses of contract.
 - f. Special conditions
 - g. Technical specifications for furnishing works / modular work stations.
 - h. Safety code.
 - i. Model rules for protection of health and sanitary arrangements for workers employed by contractors.
 - j. Preferred makes.
 - k. Annexures 1 to19.
 - l. Integrity pact.
 - m. Tender Drawings
 - n. Schedule of Quantities (SOQ)

◆ ◆ ◆ ◆ ◆ ◆ ◆ ◆

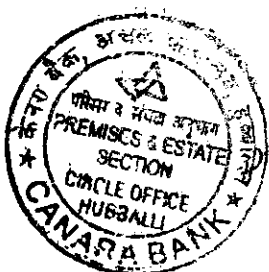

CLAUSES OF CONTRACT

Clause - 1:: DEPOSITS

THE person/persons whose tender(s) may be accepted (hereinafter called the Bidder) shall deposit a sum which together with the EMD shall equal to 2% (two percent) of the accepted tendered cost as Initial security deposit within 7 days of the issue of the letter of acceptance, in the form of Demand Draft payable to the Employer, or by way of Fixed Deposit receipt with the Canara Bank or by way of Bank Guarantee from any other Scheduled Bank in the prescribed format for the entire duration of the contract period plus the defect liability period and shall further permit the Employer at the time of making any payment to him for work done under the contract to deduct a sum of 8% of the gross amount of each running bill as Retention money till the sum along with the sum already deposited as initial security deposit will amount to security deposit of an amount equal to 10% of first Rs. One lakh, 7.5% of the next Rs. One lakh and 5% of the remainder of the accepted value of the tender subject to a maximum of Rs.25 lakhs. Such deductions will be made and held by the Employer by way of Retention money unless he has/they have deposited the full amount of Security Deposit as mentioned above in the form of Fixed Deposit Receipt issued by the Canara Bank or irrevocable Guarantee Bond of any other Scheduled Bank for the entire period of the Contract including the defect liability period. In case a fixed deposit receipt of Canara Bank is furnished by the Bidder to the Employer it shall be free from any loans or any encumbrance and shall be assigned / hypothecated to the Employer.

All compensation or the other sums of money payable by the Bidder under the terms of this contract may be deducted from, or paid by the sale of a sufficient part of his security deposit or from the interest if any, arising there from, or from any sums which may be due to or may become due to the Bidder by Government on any account whatsoever and in the event of his Security Deposit being reduced by reason of any such deduction or sale as aforesaid, the Bidder shall within 10 days make good in the cash or Guarantee Bond of a Scheduled Bank other than Canara Bank in favor of the Employer or fixed deposit receipt tendered by the Canara Bank (in case of guarantee offered by scheduled banks, the amount shall be within the financial limits prescribed by the Reserve Bank of India); any sum or sums which may have been deducted from, or raised by sale of his security deposit or any part thereof. The security deposit shall be collected from the running bills of the Bidder at the rates mentioned above and the Earnest money deposited at the time of tenders and the Initial Security Deposit will be treated as part of the Security Deposit.

Clause - 2 :: COMPENSATION FOR DELAY ::

If the Bidder fails to maintain the required progress in terms of the contract or to complete the work and clear the site on or before the contract or approved extended date of completion, he shall, without prejudice to any other right or remedy of the Employer on account of such breach, pay as agreed compensation the amount calculated at the rates stipulated below or such smaller amount as may be fixed by the authority mentioned in Schedule 'F' on the contract value of the work for every completed week that the progress remains below that specified in clause 5 or that the work remains incomplete.

This shall also apply to items or group or items for which a separate period of completion has been specified, if any.

For this purpose the term 'Contract Value' shall be value at the contract rates of the work as ordered.

Completion period (as originally stipulated)	:: 1 (One) percent per week
--	-------------------------------

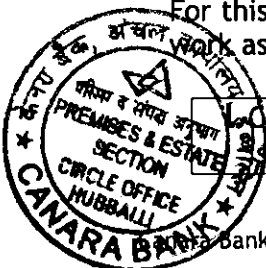

Provided always that the total amount of compensation for delay to be paid under this condition shall not exceed the undernoted percentage of the Contract Value or of the Contract Value of the item or group of items of work for which a separate period of completion is originally given:-

a) Completion period (as originally stipulated)	:: 10% (Ten percent)
---	------------------------

Clause -2.1::

Bank shall have the right to adjust set-off against any sum payable to the Bidder under this or any other contract with the Employer / Canara Bank anywhere in India / outside India.

Clause -3::

Subject to other provisions contained, the Employer may without prejudice to his any other rights or remedy against the Bidder in respect of any delay, inferior workmanship, any claims for damages and/or any other provisions of this contract or otherwise, and whether the date of completion has or has not elapsed, by notice in writing absolutely determine and cancel the contract in any of the following cases;

- i) If the Bidder having been given by the Employer and/or the Engineer-in-charge a notice in writing to rectify, reconstruct or replace any defective work or that the work is being performed in any inefficient or otherwise improper or unworkman like manner shall omit or comply with the requirement of such notice for a period of seven days thereafter.
- ii) If the Bidder being a company shall pass a resolution or the court shall make an order that the company shall be wound up or if a receiver or a manager on behalf of a creditor shall be appointed or if circumstances shall arise which entitle the court or the creditor to appoint a receiver or a manager or which entitle the court to make a winding up order.
- iii) If the Bidder has without reasonable cause failed to commence the work or has suspended the progress of the work or has failed to proceed with the work with due diligence so that in the opinion of the Employer (which shall be final and binding) he will be unable to secure completion of the work by the date for completion and continues to do so after a notice in writing of seven days from Employer.
- iv) If the Bidder fails to complete the work within the stipulated date or items of work with individual date of completion, if any stipulated, on or before such date (s) of completion and does not complete them within the period specified in a notice given in writing in that behalf by the Employer and /or Engineer-in-charge.
- v) If the Bidder persistently neglects to carry out his obligations under the contract and/or commits default in complying with any of the terms and conditions of the contract and does not remedy it or take effective steps to remedy it within 7 days after a notice in writing is given to him in that behalf by the Employer and /or Engineer-in-charge.

(i) If the Bidder commits any acts mentioned in clause 21 hereof.

Clause -3.1::

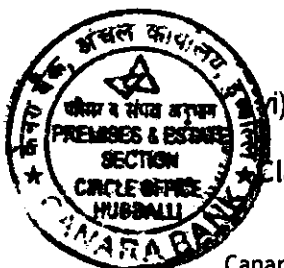

When the Bidder has made himself liable for action under any of the cases aforesaid, the Employer shall have powers::

- a) To determine or rescind the contract of which termination or rescission notice in writing to the Bidder under the hand of the Employer shall be conclusive evidence. Upon such determination or rescission, the security deposit of the Bidder shall be liable to be forfeited and shall be absolutely at the disposal of Employer.
- b) To employ labour paid by the Employer and to supply material to carry out the work or any part of the work debiting the Bidder with the cost of the labour and the price of the materials (of the amount of which cost and price certified by the Engineer-in-charge shall be final and conclusive) against the Bidder and crediting him with the value of the work done in all respects in the same manner and at the same rates as if it had been carried out by the Bidder under the terms of his contract. The certificate of the Engineer-in-charge as to the value of the work done shall be final and conclusive against the Bidder provided always that action under the sub- clause shall only be taken after giving notice in writing to the Bidder. However if the net total expenses incurred by the Employer are less than the amount payable to the Bidder at his agreement rates, the difference shall not be paid to the Bidder.
- c) After giving notice to the Bidder to measure up the work of the Bidder and to take such whole, or the balance or part thereof as shall be unexecuted out of his hands and to give it to another person to complete in which case any expenses which may be incurred in excess of the sum which would have been paid to the original Bidder if the whole work had been executed by him, of the amount of which excess the certificate in writing of the Employer shall be final and conclusive shall be borne and paid by the original Bidder and may be deducted from any money due to him by Employer under this contract or on any other contract account whatsoever or from his security deposit or the proceeds of sales thereof or a sufficient part thereof as the case maybe.

Clause -3.2::

In any such event the Bidder shall have no claim to compensation for any loss sustained by him by reason of his having purchased or procured any materials or entered into any engagements or made any advances on account or with a view to the execution of the work or the performance of the contract. And in case action is taken under any of the provisions aforesaid, the Bidder shall not be entitled to recover or be paid any sum for any work thereto or actually performed under this contract unless and until the Engineer- in-charge has certified in writing the performance of such work and the value payable in respect thereof and he shall only be entitled to be paid the value so certified. Provided further that any of the recoveries to be made when the excess cost incurred by the Employer under the action in (b) and/of (c) above is more than the Security Deposit to be forfeited, such recoveries shall be limited to the amount by which the excess cost incurred exceeds the Security deposit so forfeited.

Clause-4::

In any case in which any of the powers conferred upon the Employer under Clause-3 hereof, shall have become exercisable and the same shall not be exercised, the non-exercise thereof shall not constitute a waiver of any of the conditions hereof and such powers shall notwithstanding be exercisable in the event of any future case of default by the Bidder and the liability of the Bidder for compensation shall remain unaffected. In the event of the Employer putting in force all or any of the powers conferred in him under the preceding clause he may, if he so desires after giving a notice

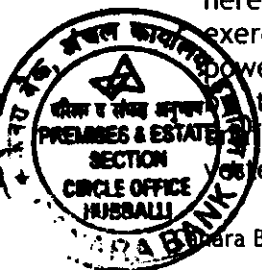

in writing to the Bidder, take possession of (or at the sole discretion of the Employer which shall be final and binding on the Bidder) use as on hire (the amount of the hire money being also in the final determination of the Employer) all or any tools, plant, materials and stores in or upon the works, or the site thereof, belonging to the Bidder, or procured by the Bidder and intended to be used for the execution of the work/or any part thereof, paying or allowing for the same in account at the contract rates, or, in the case of these not being applicable, at current market rates to be certified by the Engineer-in-charge, whose certificate thereof shall be final and binding on the Bidder, otherwise the Employer by notice in writing may order the Bidder or his clerk of the works, foreman or other authorized agent to remove such tools, plant, materials, or stores from the premises, within the time to be specified in such notice, and in the event of the Bidder failing to comply with any such requisition, the Employer may cause to remove them at the Bidder's expense or sell them by auction or private sale on account of the Bidder and at his risk in all respects and the certificate of the Engineer-in-Charge as to the expense of any such removal and the amount of the proceeds and expense of any such sale shall be final and conclusive against the Bidder.

Clause-5:: TIME AND EXTENSION FOR DELAY ::

The time allowed for execution of the Works by the Bidder as specified in the Schedule 'F' or the extended time in accordance with these conditions shall be the essence of the Contract. The execution of the works shall commence from the 7th day after the date on which the Employer issues written orders to commence the work or from the date of handing over of the site whichever is later. If the Bidder commits default in commencing the execution of the work as aforesaid, the Employer shall without prejudice to any other right or remedy available in law be at liberty to forfeit the earnest money absolutely.

Clause -5.1::

The Bidder shall submit a Time and Progress Chart and get it approved by the Engineer-in-Charge. The Chart shall be prepared in direct relation to the time stated in the Contract documents for completion of items of the works. It shall indicate the forecast of the dates of commencement and completion of various trades of sections of the work and may be amended as necessary by agreement between the Employer and the Bidder within the limitations of time imposed in the Contract documents, and further to ensure good progress during the execution of the work, the Bidder shall in all cases in which the time allowed for any work exceeds one month (save for special jobs) complete 1/8th of the whole of work before 1/4th of the whole time allowed in the contract has elapsed; 3/8th of the work before one half of such time has elapsed and 3/4th before 3/4th of such time has elapsed.

Clause-5.2:: If the works be delayed by:-

- a) Force majeure, or
- b) Excepted risk;
- c) abnormally bad weather, or
- d) serious loss or damage by fire, or
- e) civil commotion, local commotion of workmen, strike or lockout, affecting any of the trades employed on the work, or
- f) delay on the part of other Bidders or tradesmen engaged by the Employer in executing work not forming part of this Contract, or
- g) Non-availability of stores, which are the responsibility of the Employer to supply or any other cause which, in the absolute discretion of the authority mentioned in Schedule 'F' is beyond the Bidder's control,

then upon the happening of any such event causing delay, the Bidder shall

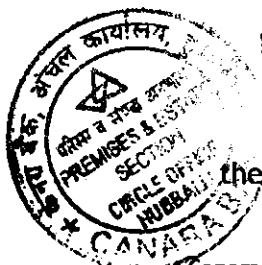

immediately give notice thereof in writing to the Employer but shall nevertheless use constantly his best Endeavour to prevent or make good the delay and shall do all that may be reasonably required to the satisfaction of the Engineer-in-charge to proceed with the works.

Clause -5.3::

Request for extension of time, to be eligible for consideration, shall be made by the Bidder in writing within 7 days of the happening of the event causing delay to the Accepting Authority. The Bidder shall also, if practicable, indicate in such a request the total period for which extension is desired, overlapping period, if any, with earlier events causing delays, net-extension required.

Clause -5.4::

In such case the authority may give a fair and reasonable extension of time for completion of work. Such extension shall be communicated to the Bidder by the Employer in writing, within 3 days of the date of receipt of such request. Non application by the Bidder for extension of time shall not be a bar for giving a fair and reasonable extension by the Employer and this shall be binding on the Bidder.

Clause - 6::

- (i) Engineer-in-charge is duty bound to, except as otherwise provided, ascertain and determine by measurement the value in accordance with the contract of work done.
- (ii) ALL measurement of all items having financial value shall be entered in Measurement Book and/or level field book so that a complete record is obtained of all works performed under the contract. All such measurement books and level books shall be with machine numbered pages with a certificate of the Engineer-in-charge regarding the name of the work and Bidder and number of pages. All such measurement books and level books shall be maintained carefully, work wise and shall be handed over to the Employer at the completion of the work.
- (iii) All measurements and levels shall be taken jointly by the Site engineer authorized by the Engineer-in-Charge and the Bidder or his authorized representative from time to time during the progress of the work and all such measurements shall be verified by the Engineer-in-Charge/Architect to verify the accuracy of the measurement and signed and dated by the Engineer-in-Charge/Architect in token thereof and by the Bidder or his representatives in token of their acceptance. Employer reserves the right to test check the measurements to the extent of 25% of measurements of each and/ or all items verified by the Engineer- in-Charge and any discrepancies are found they shall be corrected by the Employer and it shall be binding on the Bidder. If the Bidder objects to any of the measurements corrected a note shall be made to that effect with reason and signed by both parties.
- (iv) THE Bidder shall, without extra charge, provide all assistance by providing appliance, labour and other things necessary for such measurements and recording levels.

Except where any general or detailed description of the work expressly shows to the contrary, measurements shall be taken in accordance with the procedure set forth in the specifications notwithstanding any provision in the relevant Standard Method of measurement or any general or local custom. In the case of items which are not covered by specifications, measurements shall



be taken in accordance with the relevant standard method of measurement issued by the Indian Standard Institution and if for any item no such standard is available then a mutually agreed method shall be followed.

- (vi) THE Bidder shall give not less than seven days' notice to the Engineer-in-Charge or his authorized representative in-charge of the work and Employer before covering up or otherwise placing beyond the reach of measurement any work in order that the same may be test checked and correct dimensions thereof be taken before the same is covered up or placed beyond the reach of measurement and shall not cover up and place beyond reach of measurement any work without consent in writing of the Engineer-in-Charge or his authorized representative in-charge of the work and Employer who shall within the aforesaid period of seven days inspect the work, and if any work shall be covered up or placed beyond the reach of measurements without such notice having been given or the Engineer-in-Charge's and Employer consent being obtained in writing the same shall be uncovered at the Bidder's expense, or in default thereof no payment or allowance shall be made for such work or the materials with which the same was executed. No earthwork shall be started without recording initial ground levels in the level field book jointly signed by both the parties in token of acceptance.
- (vii) Whenever any payment for lead in earthwork or any other item of work is involved as an item of work, separately or together with any other item of work, the Bidder shall get the lead measured jointly by the Engineer-in-Charge before executing any work and obtain the approval in writing of the Engineer-in-Charge failing which the lead as decided by the Engineer-in-Charge and or Employer shall be treated as final and binding on the Bidder. In the case of earth work of cutting, filling and disposal, lead charts shall be prepared by the Bidder giving area and quantities to be cut and filled and lead involved and got approved in writing before executing the work failing which lead charts will be prepared by the Engineer-in-Charge as to cause most economic method of cut fill and shall be accepted for payment whether or not work is actually carried out by the Bidder accordingly.
- (viii) Engineer-in-charge or his authorized representative may cause to check the measurements recorded jointly or otherwise as aforesaid and all provisions stipulated herein above shall be applicable to such checking of measurements or levels.
- (ix) Recording of measurements of any item of work in the measurement book and/or its payment in the interim on account of final bill shall not be considered as conclusive evidence as to the sufficiency of any work or material to which it relates nor shall it relieve the Bidder from liabilities from any over measurement or defects noticed till completion of the defects liability period.

Clause 7:: NIL.

Clause - 8 ::

(i) NIL

(ii) If there is no defect in the work Engineer-in-charge shall furnish the Bidder with a final certificate of completion. Otherwise a provisional certificate of physical completion indicating defects (a) to be rectified by the Bidder and/or (b) for which payment will be made at reduced rates, shall be issued.

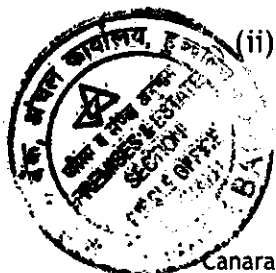

- (iii) No final certificate of completion shall be issued, nor shall the work be considered to be complete by the employer until the Bidder shall have removed from the premises on which the work shall be executed all scaffolding, surplus materials, rubbish and all huts and sanitary arrangements required for his / their work people on the site in connection with the execution of the works as shall have been erected or constructed by the Bidder(s) and cleaned off the dirt from all wood work, doors, windows, walls, floor or other parts of the building, in, upon, or about which the work is to be executed or of which he may have had possession for the purpose of the execution thereof, and not until the work shall have been measured by the Engineer-in-Charge. If the Bidder shall fail to comply with the requirements of this Clause as to removal of scaffolding, surplus materials and rubbish and all huts and sanitary arrangements as aforesaid and cleaning off dirt on or before the date fixed for the completion of work, the Engineer-in-Charge may at the expense of the Bidder remove such scaffolding, surplus materials and rubbish, etc., and dispose of the same as he thinks fit and clean off such dirt as aforesaid, and the Bidder shall have no claim in respect of any such scaffolding or surplus materials as aforesaid except for any sum actually rèches by the sale thereof.

Clause 8 (A)::

NIL Clause 8

(B):: NIL Clause

9:: NIL.

Clause -10:: MATERIALS SUPPLIED BY EMPLOYER ::

No materials will be supplied by the Employer.

Clause -10 A:: MATERIALS TO BE PROVIDED BY THE BIDDER, TESTS

(i) The Bidder shall, at his own expense, provide all materials, required for the works other than those which are stipulated to be supplied by Employer, if any.

(ii) The Bidder shall, at his own expense and without delay supply to the Engineer-in-charge samples of materials to be used on the work and shall get these approved in advance. All such materials to be provided by the Bidder shall be in conformity with the specifications laid down or referred to in the contract. The Bidder shall, if requested by the Engineer-in-charge furnish proof, to the satisfaction of the Engineer-in-Charge that the materials so comply. The Engineer-in-Charge may within thirty days of supply of samples or within such further period as he may require and so intimated to the Bidder in writing, inform the Bidder whether samples are approved by him or not. If samples are not approved, the Bidder shall forthwith arrange to supply to the Engineer-in-Charge for his approval fresh samples complying with the specifications laid down in the Contract. When materials are required to be tested in accordance with specifications, approval of the Engineer-in-Charge shall be issued after the test results indicate the specification laid down under the contract are met with.

The Bidder shall at his risk and cost submit the samples of materials to be tested analyzed and shall not make use of or incorporate in the work any materials represented by the samples until the required tests or analysis have been made and

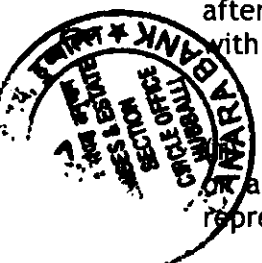

material finally accepted by the Engineer-in-Charge. The Bidder shall not be eligible for any claim or compensation either arising out of any delay in the work or due to any corrective measures required to be taken on account of and as a result of testing of materials.

(iv) THE Bidder shall at his risk and cost make all arrangements and shall provide all facilities as the Engineer-in-Charge may require for collecting and preparing the required number of samples for such tests at such time and to such place or places as may be directed by the Engineer-in-Charge and bear all charges and cost of testing unless specifically provided for otherwise elsewhere in the contract or specifications. The Employer and or Engineer-in-Charge or his authorized representative shall at all times have the right to inspect/supervise the works and access to all workshops and places where work is being prepared or from where materials, manufactured articles or machinery are being obtained for the works. The Bidder shall afford every facility and every assistance as required by the Employer/Engineer-in-Charge.

(v) The Engineer-in-Charge/Employer shall have full powers to require the removal from the premises of all materials which in his opinion are not in accordance with the specifications, and in case of default, the Employer/Engineer-in-Charge shall be at liberty to employ at the expense of the Bidder other persons to remove the same without being answerable or accountable for any loss or damage that may happen or arise to such materials. The Engineer-in-Charge/authorized representative of employer shall also have full powers to require other proper materials to be substituted thereof and in case of default the Engineer-in-Charge/ Employer may cause the same to be supplied and all cost which may attend such removal and substitution shall be borne by the Bidder.

Clause 10-B::

A. > SECURED ADVANCE ON MATERIALS:: No advance will be paid.

B. > MOBILISATION ADVANCE:: No advance will be paid.

C. > PLANT AND MACHINERY ADVANCE:: No advance will be paid.

D. > INTEREST APPLICABILITY:: Not applicable for the present case

Clause - 10 C:: ESCALATION:

The rate quoted shall be firm throughout the tenure of the contract including extension of time, if any, granted and will not be subject to any fluctuation due to increase in cost of materials, labour, etc. or any other tax. There shall be **NO ESCALATION** on the quoted rates.

The basic rates indicated in bill of quantities for material is only to facilitate the Bank to select the material. Any variation in the market price shall be absorbed by the Bidder & no extra is payable by Bank.

Clause -10 D::

The Bidder shall treat all materials obtained during dismantling of a structure, excavation of the site for a work, etc. as employer's property unless otherwise specified and such materials shall be handed over or disposed of to the best advantage of the Employer according to the instructions in writing issued by the

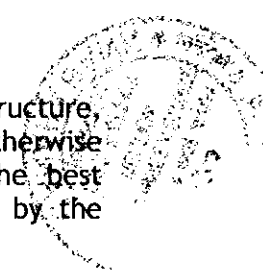
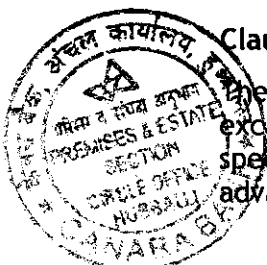

Engineer-in-Charge.

Clause -11::

(i) THE Bidder shall execute the whole and every part of the work in the most substantial and workmanlike manner and both as regards materials and otherwise in every respect in strict accordance with the specifications. "The Bidder shall also conform exactly, fully and faithfully to the design, drawings and instructions in writing in respect of the work signed by the Engineer-in- Charge and the Bidder shall be furnished free of charge one copy of the contract documents together with specifications, designs, drawings and instructions as are not included in the standard specifications of Schedule 'F' or in any Bureau of Indian Standard or any other, published standard or code or, Schedule of Rates or any other printed publication referred to elsewhere in the contract.

(ii) THE Bidder shall comply with these provisions and with due care and diligence execute and maintain the works and provide all labour and materials, tools and plants including for measurements and supervision of all works, structural plans and other things of temporary or permanent nature required for such execution and maintenance in so far as the necessity for providing these, is specified or is reasonably inferred from these presents.

(iii) The Bidder shall take full responsibility for adequacy, suitability and safety of all the works and methods of construction.

Clause - 12:: DEVIATION/ VARIATIONS EXTENT & PRICING::

The Employer and /or The Engineer- in- Charge with the specific approval of the employer shall have power:-

- (i) to make alteration in, omissions from, additions to or substitutions for the original specifications, drawings, designs and instructions that may appear to him to be necessary or advisable during the progress of the work, and
- (ii) to omit a part of the works or Item of the works or reduce the quantity in case of non-availability of a portion of the site or for any other reasons and the Bidder shall be bound to carry out the works in accordance with any instructions given to him in writing signed by the Engineer-in-Charge and such alterations, omissions, additions or substitution shall form part of the contract as if originally provided therein and any altered, additional or substituted work which the Bidder may be directed to do in the manner specified above as part of the works, shall be carried out by the Bidder

on the same conditions in all respects including price on which he agreed to do the main work without any extra compensation except as hereafter provided:

(a) No work which radically changes the original nature of the contract shall be ordered by the Engineer-in-Charge as a deviation.

(b) In the event of any deviation being ordered which in the opinion of the Bidder changes the original nature of the Contract, he shall within fifteen days of having been so ordered bring this to the notice of the Engineer-in-Charge with the reasons but nevertheless carry it out and the disagreement as to the nature of work and the rate to be paid therefore shall be resolved in accordance with Clause 25.



Clause -12.1::

The time for completion of the works shall, in the event of any deviations resulting in additional cost over the contract sum being ordered, be extended by the employer if requested by the Bidder as follows::

- a) In the proportion which the additional cost of the altered, additional or substituted work, bears to the original Contract sumplus
- b) 25% of the time calculated in (a) above or such further additional time as may be considered reasonable on the recommendations of by the Engineer-in-Charge.

Rates for such altered, additional or substituted work shall be determined by the Employer as follows on the recommendations of Engineer-in-Charge:

(i) If the rate for altered, additional or substituted item of work is specified in the Schedule of Quantities, the Bidder shall carry out the altered, additional or substituted item at the same rate. In the case of composite tenders, where two or more schedules of quantities may form part of the contact, the applicable rate shall be taken from the schedule of quantities of that particular part in which the deviation is involved, failing that at the lowest applicable rate for the same item of work in the other Schedules of Quantities.

(ii) If the rate for any altered, additional or substituted item of work is not specified in the Schedule of Quantities, the rate for that item shall be derived from the rate for the nearest similar item specified therein. In case of composite tenders where two or more schedule of quantities form part of the contract, the rate shall be derived from the nearest similar item in the Bills of Quantities of the particular part of works in which the deviation is involved failing that from the lowest of the nearest similar items in other schedule of quantities.

(iii) If the rate for altered, additional or substituted item of work cannot be determined in the manner specified in sub-paras (i) and (ii) above, then such item of works shall be carried out at the rate entered in the Schedule of Rates mentioned in Schedule 'F' plus/minus the percentage by which the tendered amount of the works actually awarded is higher or lower than the estimated amount of the works actually awarded.

(iv) If the rate for any altered, additional or substituted item of work cannot be determined in the manner specified in sub-paras (i) to (iii) above, then the rate for such item of work shall be derived from the Schedule of Rates specified in sub-para (iii) above plus/minus the percentage mentioned in the sub-para (iii)above. In the case of materials issued by the Employer, issue rates of materials, with storage charges recovered, enhanced by two and a half percent for profits and overheads shall be adopted in place of schedule Rate plus percentage specified in sub-Para(iii), Provided always that if rate(s) for part (s) of an item (s) for such part(s) shall be determined by the Engineer-in-Charge on the basis of the purchase price as supported by the vouchers plus ten per cent for profits and overheads unless the Engineer-in-Charge finds the purchase price unreasonable. In the latter event the price shall be determined on the basis of market rate(s) prevailing during the fortnight following the date of the order plus ten per cent for profit and overhead.

If the rate for any altered, additional or substituted item of work cannot be determined in the manner specified in Sub-Paras(i) to (iv) above, the Bidder shall, within 7 days of the date of receipt of the order to carry out the said work, inform

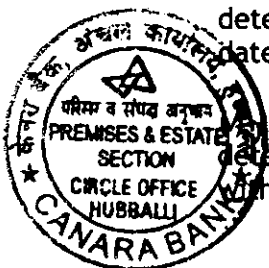

the Engineer-in-Charge of the rate which he proposes to claim for such item of work, supported by analysis of the rate claimed, and the Engineer- in-Charge shall within three months thereafter, after giving due consideration to the rate claimed by the Bidder, determine the rate on the basis of market rate(s). In the event of the Bidder failing to inform the Engineer-in-Charge within the stipulated period of time, the rate which he proposes to claim, the rate for such item shall be determined by the Engineer-in-Charge on the basis of market rate (s)only.

(M) A. Except in case of items relating to foundations as it exists at the time of commencement of work as per Clause B as under, the quantities of which may change due to site conditions, provisions contained in sub-conditions (i)to

(v) above shall not apply to:-

(a) that value of any contract item, substituted item or contract-cum-substituted item as is in excess of the original value of the item plus the percentage mentioned in Schedule `F' or Rs.20,000/- whichever is higher.

(b) The value of all items not already included in the Contract, as is in excess of the percentage mentioned in Schedule `F' or Rs.40,000/- whichever is higher.

(vi) B. In case of items relating to foundations as it exists at the time of commencement of work, quantities of which may change due to site conditions, provisions contained in sub-conditions (i) to (v) above shall not apply to

(a) Value of any items of any individual trade which exceed by more than the percentage maintained in Schedule `F' of the value of that trade included in the Contract as a whole, unless the Bidder and the Engineer-in-Charge agree to a higher percentage for any particular item.

(b) The value of item not included in the Contract in excess of 5% of the contract sum or Rs.40,000/- whichever is higher.

NOTE: - Individual trade means the sub-heads into which the Schedule of Quantities as provided in the Contract has been divided and in the absence of any such provisions in the contract the sub-heads as given in the Schedule of Rates.

Clause -12.1.2:: For the purpose of operation of clause 12.1 (vi), the following works shall be treated as works relating to foundation.

- (a) For buildings, compound walls plinth level or 1.2 meters (4 feet) above ground level whichever is lower excluding items of flooring and D.P.C. but including base concrete below the floors.
- (b) For abutments, piers, retaining walls of culverts and bridges, walls of water reservoirs the bed of floor level.
- (c) For retaining walls where floor level is not determined, 1.2 meters above the average ground level or bed level.
- (d) For roads all items of excavation and filling including treatment of sub-base and soling work.

Clause -12.2 :: In the case of contract items, substituted items, contract cum substituted items or additional items which exceed the limits laid down in sub Para (vi) of Condition 12.1 above, the Bidder may, within fifteen days of receipt of order or occurrence of the excess claim revision of the rates, supported by proper analysis, for the work in excess of the above mentioned limits, provided that if the rates so claimed are in excess of the rates specified in the Schedule of Quantities. Engineer-

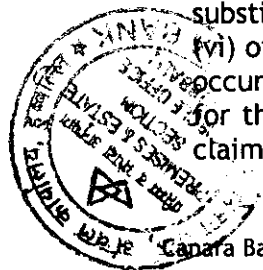

in-charge shall, within sixty days of receipt of the claims supported by analysis, after giving consideration to the analysis of the rates submitted by the Bidder, determine the rates on the basis of the market rates and the Bidder shall be paid in accordance with the rates so determined. In the event of the Bidder failing to claim revision of rates within the stipulated period, or if the rates determined by the Engineer- in-charge, No claims shall be entertained after the claim of the final bills.

Clause -12.3:: The provisions of the preceding paragraph shall also apply to the decrease in the rates of items. For the work in excess of the limits laid down in sub Para(vi) of Condition 12.1 in accordance with the provisions or sub-Paras(i) to (iv) of Condition 12.1 and the Engineer-in-Charge may after giving notice to the Bidder within one month of the occurrence of the excess and after taking into consideration any reply received from him within fifteen days of receipt of the notice revise the rates for the work in question within **one month** of expiry of the said period of fifteen days having regard to the market rates.

Clause -12.4:: The Bidder shall send to the Engineer-in-Charge once in every month till completion date account giving complete details of all claims for additional payments to which the Bidder may consider himself entitled and of all additional work ordered by the Engineer-in-Charge which he has executed during the preceding quarter failing which the Bidder shall be deemed to have waived his right and to have no claim in the matter.

Clause -12.5:: No increase or decrease of rates under clause 12.1, 12.2 and 12.3 shall be made unless within the stipulated period after the order of variation and before the commencement of such quantities a notice shall have been given in writing by the party claiming increase or decrease of rates.

Clause -13:: FORECLOSURE OF CONTRACT IN FULL OR IN PART

(i) The employer shall give notice in writing at any time after acceptance of the tender, if the Employer shall decide to abandon or reduce the scope of the works for any reason whatsoever and hence not require the whole or any part of the works to be carried out, to that effect to the Bidder and the Bidder shall act accordingly in the matter and the Bidder shall have no claim to any payment of compensation or otherwise whatsoever, on account of any profit or advantage which he might have derived from the execution of the works in full but which he did not derive in consequence of the foreclosure of the whole or part of the works.

(ii) The employer may pay to the Bidder at Contract rates full amount for works executed at Site and, in addition, a reasonable amount as certified by the Engineer-in-Charge for the Items hereunder mentioned which could not be utilized on the work to the full extent in view of the foreclosure and the Bidder expressly agrees for such payment without demur.

(a) Any expenditure incurred on preliminary site work, e.g., temporary access roads, temporary labour huts, staff quarters and site office.

(b) Employer shall have the option to take over Bidder's materials or any part thereof either brought to site or of which the Bidder is legally bound to accept delivery from suppliers (for incorporation in or incidental to the work). For materials taken over or to be taken over by the Employer cost of such materials as detailed by Engineer-in-Charge shall be paid. The cost shall, however, take into account purchase price, cost of transportation and deterioration or damage which may have been caused to materials whilst in the custody of the Bidder.



- (c) Reasonable compensation for transfer of T & P from Site to Bidder's permanent stores or to his other Works, whichever is less. If T & P are not transported to either of the said places, no cost of transportation shall be payable.
- (d) Reasonable compensation for repatriation of Bidder's Site staff and imported labour to the extent necessary.
- (e) The reasonable amount of items on (a), (c) and (d) above shall not be in excess of 2% of the cost of the work remaining incomplete on the date of closure, i.e., total stipulated cost of the work as per accepted tender less the cost of work actually executed under the contract and less the cost of Bidder's materials at site taken over by the Employer as per item (b) above. Provided always that against any payments due to the Bidder on this account or otherwise, the Employer shall be entitled to recover to be credited with any outstanding balances due from Bidder for advances paid in respect of any tool, plants and materials and any other sums which at the date of termination were recoverable by the employer from the Bidder under the terms of the contract.
- (iii) If any materials supplied by the Employer are rendered surplus, the same except normal wastage shall be returned by the Bidder to the Employer at the rates not exceeding those at which these were originally issued less allowance for any deterioration or damage which may have been caused whilst the materials were in the custody of the Bidder. In addition cost of transporting such materials from site to the Employers stores, if so required by the Employer shall be paid.
- (iv) THE Bidder shall, if required by the Employer/Engineer-in-Charge furnish to him books of account, wage books, time sheets and other relevant documents and evidence as may be necessary to enable him to certify the reasonable amount payable under this Condition.

Provided always that against any payments due to the Bidder on this account or Otherwise, the Employer shall be entitled to recover or be credited with any outstanding balances due from the Bidder for advance paid in respect of any tool, plants and materials and any other sums which at the date of termination were recoverable by the Government from the Bidder under the terms of the contract.

A compensation for such eventuality, on account of damages etc. shall be payable @ 0.5% of cost of work remaining incomplete on date of closure i.e. total stipulated cost of the work less the cost of work actually executed under the contract shall be payable.

Clause -14:: CANCELLATION OF CONTRACT IN FULL OR PART ::

i. > If Bidder ::

- (a) at any time makes default in proceeding with the works or any part of the work with due diligence or poor quality of work / workmanship or non compliance of contract specifications and continues to do so after a notice in writing of 7 days from the Employer and or Engineer-in-Charge; or

commits default in complying with any of the terms and conditions of the Contract and does not remedy it or take effective steps to remedy it within 7 days after a notice in writing is given to him in that behalf by the Employer and or Engineer-in-Charge; or

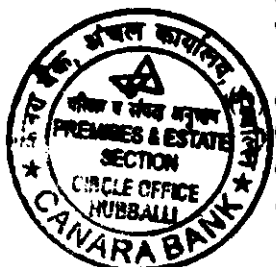

- (c) fails to complete the works or items of work with individual dates of completion, on or before the date(s) of completion, and does not complete them within the period specified in a notice in writing is given to him in that behalf by the Employer and or Engineer-in-Charge; or
- (d) shall offer or give or agree to give to any person in Bank service or to any other person on his behalf any gift or consideration of any as an inducement or reward for doing or for bearing to do or for having done or forborne to do any act in relation to the obtaining or execution of this or any other Contract for the Employer or;
- (e) shall enter into a Contract with the Bank in connection with which commission has been paid or agreed to be paid by him or his knowledge, unless the particulars of any such commission and the terms of payment thereof have been previously disclosed in writing to the Employer/Engineer-in-Charge; or
- (f) shall obtain a Contract with the Employer as a result of wrong tendering or other non-bona-fide methods of competitive tendering; or being an individual, or in a firm, any partner thereof shall at any time be adjudged insolvent or have a receiving order or order for administration of his estate made against him or shall take any proceedings for liquidation or composition (other than a voluntary liquidation for the purpose or amalgamation or reconstruction) under any Insolvency Act for the time being in force or make any conveyance or assignment of his effects or composition or arrangement for the benefit of his creditors or purport so to do, or if any application be made under any Insolvency Act for the to me being in force for the sequestration of his estate or if a trust deed be executed by him for benefit of his creditors; or
- (g) being a company, shall pass a resolution or the Court shall make an order for the winding up of the company or a receiver or manager on behalf of the debenture holders or others shall be appointed or circumstances shall arise which entitle the Court or debenture holders to appoint a receiver or manager; or
- (h) shall suffer an execution being levied on his goods and allow it to be continued for a period of 21 days; or
- (i) assigns, transfers, sublets (engagement of labour on a piece-work basis or of labour with materials not to be incorporated in the work, shall not be deemed to be subletting) or otherwise parts with or attempts to assign, transfer sublet or otherwise parts with the entire works or any portion thereof without the prior written approval of the Accepting Authority;
- (j) the Accepting Authority may, without prejudice to any other right or remedy which shall have accrued or shall accrue thereafter to the Employer, by a notice in writing cancel the contract as a whole or only such of items in default from the Bidder.

The Employer / Engineer-in-Charge shall on such cancellation by the accepting authority have powers to, for which the Bidder shall hereby unconditionally agree :-

- (a) to take possession of the Site and any materials, constructional plant, implements, stores, etc., thereon; and/or
- (b) to carry out the incomplete work by any means at the risk and cost of the Bidder.

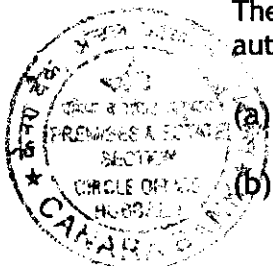

ii. > On cancellation of the Contract in full or in part, the Engineer-in-Charge shall determine what amount, if any, is recoverable from the Bidder for completion of the works or part of the Works or incase the Works or part of the Works is not to be completed the loss or damage suffered by the Employer. In determining the amount, credit shall be given to the Bidder for the value of the work executed by him up to the time of cancellation, the value of Bidders' materials taken over and incorporated in the work and use of tackle and machinery belonging to the Bidder.

iii. > Any excess expenditure incurred or to be incurred by the Employer in completing the Works or part of the Work or the excess, loss or damages suffered or may be suffered by the Employer as aforesaid after allowing such credit shall without prejudice to any other right or remedy available to Employer in law be recovered from any money due to the Bidder on any account, and if such moneys are not sufficient the Bidder shall be called upon in writing and shall be liable to pay the same within 30days.

iv. > If the Bidder shall fail to pay the required sum within the aforesaid period of 30 days, the Engineer-in-Charge with the approval of the Employer shall have the right to sell any or all of the Bidder's unused materials, constructional plant, implements, temporary buildings, etc. and adjust the proceeds of sale thereof towards the satisfaction of any sums due from the Bidder under the Contract and if thereafter there be any balance outstanding from the Bidder, it shall be recovered in accordance with the provisions of the Contract.

v. > Any sums in excess of the amounts due to the Employer and unsold materials, constructional plant, etc., shall be returned to the Bidder, provided always that if cost or anticipated cost of completion by the Employer of the Works or part of the Works is less than the amount which the Bidder would have been paid had he completed the Works or part of the Works, such benefit shall not accrue to the Bidder.

In the event of above course being adopted by the Engineer-in-Charge, the Bidder shall have no claim to compensation for any loss sustained by him by reason of his having purchased or procured any materials or entered into any engagements or made any advance on any account or with a view to the execution of the work or the performance of the contract.

Clause -15 :: SUSPENSION OF WORK ::

a) The Bidder shall, on receipt of the order in writing of the Employer, whose decision shall be final and binding on the Bidder, suspend the progress of the Works or any part thereof for such time and in such manner as the Employer may consider necessary so as not to cause any damage or injury to the work for any of the following reasons::

- (i) on account of any default on the part of the Bidder or;
- (ii) for proper execution of the works or part thereof for reasons other than the default of the Bidder; or
- (iii) for safety of the Works or part thereof.

The Bidder shall, during such suspension, properly protect and secure the Works to the extent necessary and carry out the instructions given in that behalf by the Engineer-in-Charge.

If the suspension is ordered for reasons (ii) and (iii) in sub para (a)above.

the Bidder shall be entitled to an extension of time equal to the period of every such suspension PLUS 25%, for completion of the item or group of

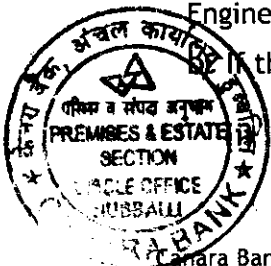

items of work for which a separate period of completion is specified in the Contract and of which the suspended work forms a part ; and

- (ii) If the total period of all such suspensions in respect of an item or group of items of work for which a separate period of completion is specified in the Contract exceeds thirty days, the Bidder shall, in addition, be entitled to such compensation as the Employer/Engineer-in-Charge may consider reasonable, in respect of salaries and/or wages paid by the Bidder to his employees and labour at Site, remaining idle during the period of suspension, adding thereto the percentage mentioned in Schedule 'F' to cover all other expenses including indirect expenses of the Bidder, provided the Bidder submits his claim supported by details to the Employer within fifteen days of the expiry of the period of 30days.

c) If the Works or part thereof is suspended on the orders of the Employer for more than three-months at a time, except when suspension is ordered for reason (i) in sub-Para (a) above, the Bidder shall after receipt of such order serve a written notice on the Employer requiring permission within fifteen days from receipt by the Employer of the said notice, to proceed with the Works or part thereof in regard to which progress has been suspended. If such permission is not granted within that time, the Bidder, if he intends to treat the suspension, where it affects only a part of the works as an omission of such part by the Employer or where it affects whole of the Works, as an abandonment of the Works by the Employer shall within ten days of expiry of such period of 15 days give notice in writing of his intention to the Employer. In the event of the Bidder treating the suspension as an abandonment of the Contract by the Employer, he shall have no claim to payment of any compensation on account of any profit or advantage which he might have derived from the execution of the work in full but which he could not derive in consequence of the abandonment. He shall, however, be entitled to such compensation, as the Engineer-in-Charge may consider reasonable, in respect of salaries and/or wages paid by him to his employees and labour at Site, remaining idle in consequence and of materials collected which could not be utilized on the Works, adding to the total thereof the percentage mentioned in Schedule 'F' to cover all other expenses including indirect expenses of the Bidder provided the Bidder submits his claim supported by details to the Employer within 30 days of the expiry of the period of 3 months ; Provided, further, that the Bidder shall not be entitled to claim any compensation from the Employer for the loss suffered by him on account of delay by the Employer in the supply of materials in Schedule 'B' where such delay is covered by difficulties relating to the supply of wagons, force majeure including non-allotment of such materials by controlling authorities, acts of God, acts of enemies of the state/country or any reasonable cause beyond the control of the Employer.

Clause -16:: INSPECTION ::

(i) All works under or in course of execution or executed in pursuance of the Contract shall be at all times be open and accessible to the inspection and supervision of the Engineer-in-Charge and or Employer, his authorized subordinates in charge of the work and to all his superior officers of the Quality Control Organization of the Employer or any Consultant of the Employer and of the Chief Technical Examiner's Office under Central Vigilance Commission.

(ii) The Bidder shall at all times during the usual working hours and at all other times at which reasonable notice of the visit of such officers has been given to the Bidder, either himself be present to receive orders and instructions and inspections or have a responsible agent duly accredited in writing present for that purpose. Orders given to the Bidder's agent shall be considered to have the same force as if they had been given to the Bidder himself.

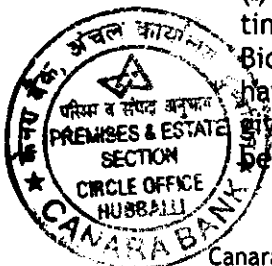

(iii) IF it shall appear to the Engineer-in-Charge and or Employer or his authorized subordinates in-charge of the work or to the Engineer in charge of Quality Control or any Consultant of the Employer or to the Chief Technical Examiner, that any work has been executed with unsound, imperfect, or unskillful workmanship, or with materials or articles provided by him for the execution of the work which are unsound or of a quality inferior to that contracted or otherwise not in accordance with the contract, the Bidder shall, on demand in writing, which shall be made within twelve months of the completion of the work, from the Employer and or Engineer-in-Charge specifying the work, materials or articles complained of notwithstanding that the same may have been passed, certified and paid for, forthwith rectify, or remove and reconstruct the work so specified in whole or in part, as the case may require or as the case may be, remove the materials or articles so specified and provide other proper and suitable materials or articles at his own charge and cost. In the event of the Bidder failing to do so within a period specified by the Employer / Engineer-in-Charge in his demand aforesaid, then the Bidder shall be liable to pay compensation at the same rate as under the clause 2 for non-completion of the work in time for this default.

IN such case the Engineer-in-Charge may not accept the item of work at the rates applicable under the contract but may accept such items at reduced rates as the Employer or the competent authority may consider reasonable during the preparation of on account bills or final bill if the item is so acceptable without detriment to the safety and without substantially affecting the utility of the item and the structure or he may reject the work outright without any payment and/or get it and other connected and incidental items rectified, or removed and re executed at the risk and cost of the Bidder. Decision of the Engineer-in-Charge to be conveyed in writing in respect of the same will be final and binding on the Bidder.

Clause -17::

If the Bidder or his working people or servants shall break, deface, injure or destroy any part of building in which they may be working, or any building, road, road curb, fence, enclosure, water pipe, cables, drains, electric or telephone post or wires, trees, grass or grass land, or cultivated ground contiguous to the premises on which the work or any part is being executed, or if any damage shall happen to the work while in progress, from any cause whatever or if any defect, shrinkage or other faults appear in the work within twelve months after a certificate final or otherwise or its virtual completion shall have been given by the Employer/Engineer-in-Charge as aforesaid arising out of defect or improper materials or workmanship the Bidder shall upon receipt of a notice in writing on that behalf make the same good at his own expense or in default the Employer/Engineer-in-Charge cause the same to be made good by other workmen and deduct the expense from any sums that may be then or at any time thereafter may become due to the Bidder, or from his security deposit, except for the portion pertaining to asphaltic work which is governed by sub-Para (iii) of Clause 35 or the proceeds of sale thereof or of a sufficient portion thereof. Fifty (50) percent of the security deposit except the portion pertaining to asphaltic work which is governed by sub-Para

II. of Clause 35, water proofing work , anti-termite work which are governed by clause 19 of special conditions may be refunded after the expiry of six months (after the virtual completion of the work) or after the final bill has been prepared and passed whichever is later, and the remaining fifty (50) percent of the Security Deposit shall be refunded fourteen (14) days after the expiry of the defect liability period of twelve months after the completion of the work except for water proofing & anti-termite works provided that all the works are carried out as per specifications and condition of contract and all the defect and damages are certified satisfactorily to the satisfaction of the Employer/Engineer-in-Charge.

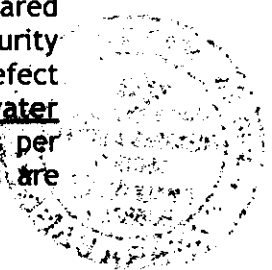
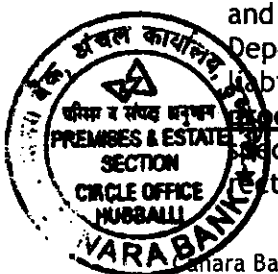

Clause -18::

THE Bidder shall provide at his own cost all materials (except such special materials, if any as may in accordance with the contract be supplied by the Employer), plant, tools, appliances, implements, ladders, cordage, tackle, scaffolding and temporary works required for the proper execution of the work, whether original, altered or substituted and whether included in the specification or other documents forming part of the contract or referred to in these conditions or not, or which may be necessary for the purpose of satisfying or complying with the requirements of the Engineer-in-Charge as to any matter as to which under these conditions he is entitled to be satisfied, or which he is entitled to require together with carriage there for to and from the work. The Bidder shall also supply without charge the requisite number of persons with the means and materials, necessary for the purpose of setting out works, and counting, weighing and assisting the measurement for examination at doing the same may be provided by the Engineer-in-Charge at the expense of the Bidder and the expenses may be deducted, from any money due to the Bidder, under this contract or otherwise and or from his security deposit or the proceeds of sale thereof, or of a sufficient portions thereof.

Clause -18 A::

In every case in which by virtue of the provisions sub-section of Section 12, of the Workmen's Compensation Act, 1923, Employer is obliged to pay compensation to a workman employed by the Bidder, in execution of the works, Employer shall be entitled to recover from the Bidder the amount of the compensation so paid; and, without prejudice to the rights of the Employer under sub-Section 12, of the said Act, Employer shall be at liberty to recover such amount or any part thereof by deducting it from the security deposit or from any sum due by the Employer to the Bidder whether under this contract or otherwise. The Employer shall not be bound to contest any claim made against it under Section 12, of the said Act, except on the written request of the Bidder and upon his giving to the Employer full security for all cost for which the Employee might become liable in consequence of contesting such claim.

Clause -18 B::

In every case in which by virtue of the provisions of the Contract Labour (Regulation and Abolition) Act 1970, and of the Contract Labour (Regulation and Abolition) Central Rules, 1971, the Employer is obliged to pay any amounts of wages to a workman employed by the Bidder in execution of the works, or to incur any expenditure in providing welfare and health amenities required to be provided under the above said Act and the rules under Clause 19H or under the Bidders' Labour Regulations, or under the Rules framed by the State or Central Employer from time to time for the protection of health and sanitary arrangements for workers employed by the Bidders, the Employer shall be entitled to recover from the Bidder the amount of wages so paid or the amount of expenditure so incurred; and without prejudice to the rights of the Employer under sub-Section (2) of Section 20, and sub-Section (4) of Section 21, of the Contract Labour (Regulation and Abolition) Act, 1970, the Employer shall be at liberty to recover such amount or any part thereof by deducting it from the security deposit or from any sum due by the Employer to the Bidder whether under this contract or otherwise. The Employer shall not be bound to contest any claim made against it under sub- Section (1) Section 20 and sub-Section (4) of Section 21, or any other provisions of the said Act, except on the written request of the Bidder and upon his giving to the Employer full security for all costs for which the Employer might become liable in contesting such claim.

Clause -19::

The Bidder shall obtain a valid license under the Contract Labour (R&A) Act, 1970.

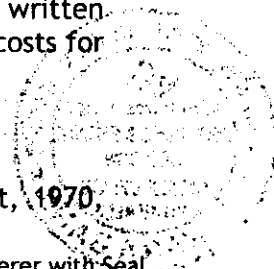

and the Contract Labour (Regulation and Abolition) Central Rules, 1971, before the commencement of the work, and continue to have a valid license until the completion of the work. The Bidder shall also abide by the provisions of the Child Labour (Prohibition and Regulation) Act, 1986.

The Bidder shall also comply with the provisions of the building and other Construction Workers (Regulation of Employment & Conditions of Service) Act, 1996 and the building and other Construction Workers Welfare Cess Act, 1996.

Any failure to fulfill these requirements shall attract the penal provisions of this contract arising out of the resultant non-execution of the work.

Clause -19 A::

NO labour below the age of eighteen years shall be employed on the work.

Clause -19 B:: PAYMENT OF WAGES ::

a) The Bidder shall pay to labour employed by him either directly or through sub-Bidders, wages not less than fair wages as defined as per the provisions of the Contract Labour (Regulation and Abolition) Act 1970, and the Contract Labour (Regulation and Abolition) Central Rules, 1971 wherever applicable. Such wages paid shall not less than the wages fixed by the state and/or Central Employer under the Minimum Wages Act applicable to the work.

b) The Bidder shall, notwithstanding the provisions of any contract to the contrary, cause to be paid fair wage to labour indirectly engaged on the work, including any labour engaged by his sub-Bidders in connection with the said work, as if the labour had been immediately employed by him.

c) In respect of all labour directly or indirectly employed in the works for performance of the Bidder's part of this contract, the Bidder shall comply with or cause to be complied with the Bidder's Labour Regulations made by Employer and or the Employer (State and Central) from time to time in regard to payment of wages, wage period, deductions from wages, recovery of wages not paid and deductions unauthorisedly made, maintenance of wage books or wage slips, publication of scale of wages and other terms of employment, inspection and submission of periodical returns and all other matters of the like nature or as per the provisions of the Contract Labour (Regulation and Abolition) Act, 1970, and the Contract Labour (Regulation and Abolition) Central Rules, 1971, wherever applicable.

d) (i) The Employer and/or his Engineer-in-Charge concerned shall have the right to deduct from the moneys due to the Bidder any sum required or estimated to be required for making good the loss suffered by a worker or workers by reason of non-fulfillment of the conditions of the contract for the benefit of the workers, non-payment of wages or of deductions made from his or their wages which are not justified by their terms of the contract or non-observance of the Regulations.

III. Under the provision of Minimum Wages (Central) Rules 1950, the Bidder is bound to allow to the labour directly or indirectly employed in the works one way rest for 6 days continuous work and pay wages at the same rate as for duty. In the event of default the Employer and or Engineer-in-Charge shall have the right to deduct the sum or sums not paid on account of wages for weekly holidays to any labour and pay the same to the persons entitled thereto from any money due to the Bidder by the Employer

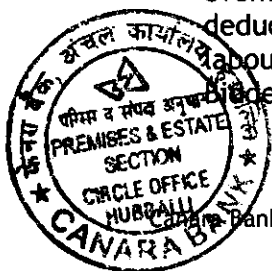

In cases where the state Government or Government of the Union of India where all inclusive minimum daily wages are fixed and such wages are inclusive of wages for the weekly day of rest, the question of extra payment for weekly holiday would not arise.

e) The Bidder shall comply with the provisions of the payment of Wages Act, 1936, Minimum Wages Act, 1948, Employees Liability Act, 1938, Workmen's Compensation Act, 1923, Industrial Disputes Act, 1947, Maternity Benefits Act, 1961, and the Bidders' Labour (Regulation and Abolition) Act 1970, or the modifications thereof or any other laws relating thereto and the rules made there under from time to time.

f) The Bidder shall indemnify and keep indemnified the Employer against payments to be made under and for the observance of the laws aforesaid and the Bidders' Labour Regulations without prejudice to his right to claim indemnify from his sub-Bidders.

g) The laws aforesaid shall be deemed to be a part of this contract and any breach thereof shall be deemed to be a breach of this contract.

h) Whatever is the minimum wage for the time being, or if the wage payable is higher than such wage, such wage shall be paid by the Bidder to the workmen directly without the intervention of Jamadar and that Jamadar shall not be entitled to deduct or recover any amount from the minimum wage payable to the workmen as and by way of commission or otherwise.

The Bidder shall ensure that no amount by way of commission or otherwise is deducted or recovered by the Jamadar from the wage of workmen.

Clause -19 C::

IN respect of all labour directly or indirectly employed in the work for the performance of the Bidder's part of this contract, the Bidder shall at his own expense arrange for the safety provisions as per Government and Employer's safety Code framed from time to time and shall at his own expense provide for all facilities in connection therewith. In case the Bidder fails to make arrangement and provide necessary facilities as aforesaid he shall be liable to pay a penalty of Rs.200/- for each default and in addition the Engineer-in-Charge shall be at liberty to make arrangement and provide facilities as aforesaid and recover the costs incurred in that behalf from the Bidder.

Clause -19 D::

THE Bidder shall submit by the 4th and 19th of every month, to the Engineer- in-Charge a true statement showing in respect of the second half of the preceding month and the first half of the current month respectively.

- (1) The number of labourers employed by him on the work.
- (2) Their working hours,
- (3) The wages paid to them,
- (4) The accidents that occurred during the said fortnight showing the circumstances.
- (5) The number of female workers who have been allowed Maternity Benefit according to Clause 19F and the amount paid to them.

Billings which the Bidder shall be liable to pay to Employer a sum not exceeding Rs.200/- for each default or materially incorrect statement. The decision of the Engineer-in-Charge shall be final in deducting from any bill due to the Bidder the amount levied as fine and be binding on the Bidder.

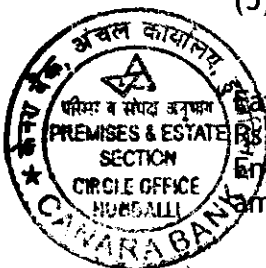

Clause -19 E::

The Bidder shall comply with or cause to be complied with all the rules framed by the State and or Central Government from time to time for the protection of health and sanitary arrangements for workers employed, in respect of all labour directly or indirectly employed in the works for the performance of the Bidder's part of this contract.

Clause -19 F::

The Bidder shall maintain appropriate records for LEAVE and pay during leave and the same shall be regulated as per relevant/latest labour laws.

Clause -19 G :: DEFAULT AS TO REGULATIONS/RULES ::

(i) IN the event of the Bidder(s) committing a default or breach of any of the provisions of Bidders' about Regulations and Model Rules for the protection of health and sanitary arrangements for the workers as amended from time to time or furnishing any information or submitting or filling any statement under the provisions of the above Regulations and Rules which is materially incorrect, the Bidder shall without prejudice to any other liability pay to the Employer a sum not exceeding Rs.100/- for every default, breach or furnishing, making, submitting, filing such materially incorrect statements and in the event of the Bidder(s) defaulting continuously in this respect, the penalty may be enhanced to Rs.50/- per day for each day of default subject to a maximum of 5 percent of the estimated cost of the work put to tender. The decision of the Engineer-in-Charge / Employer shall be final and binding on the Bidders.

(ii) Should it appear to the Engineer-in-Charge/ Employer that the Bidder(s) is/are not properly observing and complying with the provisions of the Bidder's Labour Regulations and Model Rules and the provisions of the Contract Labour (Regulation and Abolition) Act 1970, and the Contract Labour (R & A) Central Rules 1971, for the protection of health and sanitary arrangements for work-people the Engineer-in-Charge/ Employer shall have power to give notice in writing to the Bidder(s) requiring that the said Rules be complied with and the amenities prescribed therein be provided to the work-people within a reasonable time to be specified in the notice. If the Bidder(s) shall fail within the period specified in the notice to comply with and/observe the said Rules and to provide the amenities to the work-people as aforesaid, the Engineer-in-Charge shall have the power to provide the amenities hereinbefore mentioned at the cost of the Bidder(s). The Bidder(s) shall erect, make and maintain at his/their own expenses and approved standards all necessary huts and sanitary arrangements required for his/their work-people on the site in connection with the execution of the works, and if the same shall not have been erected or constructed, according to approved standards, the Engineer-in-Charge/ Employer shall have power to give notice in writing to the Bidder(s) requiring that the said huts and sanitary arrangements be remodeled and/or reconstructed according to approved standards, and if the Bidder(s) shall fail to remodel reconstruct such huts and sanitary arrangements according to approved standards within the period specified in the notice, the Engineer-in-Charge/ Employer shall have the power to remodel or reconstruct such huts and sanitary arrangements according to approved standards at the cost of the Bidder(s).

Clause -19 H :: CAMP ::

Facility like toilets, water supply, rest rooms shall be provided for the labours as per following regulations for similar works.

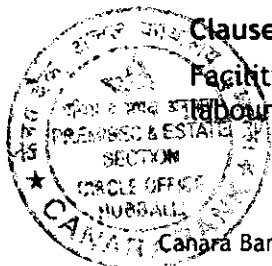

Clause -19 - I :: COMPLIANCE AS TO EMPLOYEES' SERVICE ::

THE Engineer-in-Charge/ Employer may require the Bidder to dismiss or remove from the site of the work any person or persons in the Bidders' employment who may be incompetent or misconduct himself or undesirable person and the Bidder shall forthwith comply with such requirements.

Clause -19- K :: ILLEGAL OCCUPATION ::

The Bidder shall undertake to see that the building under construction is not occupied by anybody unauthorisedly during construction, and is handed over to the Employer through his Engineer-in-Charge with vacant possession of complete building. If such building though completed is occupied illegally, then the Employer shall have the option to refuse to accept the said building/buildings in that position, and delay in acceptance on this account will be treated as delay in completion and for such delay a levy upto 5% of estimated cost put to tender may be imposed by the Employer whose decision shall be final both with regard to the justification and quantum and be binding on the Bidder.

However, the Employer may request the Bidder through a notice to remove the illegal occupation any time on or before construction and delivery.

Clause - 20 :: COMPLIANCE WITH STATUTE ::

THE Bidder shall comply with all the provisions of the Minimum Wages Act, 1948, Contract Labour (Regulation and Abolition) Act 1970, EPF & MP Act 1952, ESI Act and amendments from time to time and rules framed there under and other labour laws affecting contract labour that may be brought into force from time to time.

Clause - 21 :: ASSIGNMENT ::

The contract shall not be assigned or sublet without the written approval of the Employer. And if the Bidder shall assign or sublet his contract, or attempt to do so, or become insolvent or commence any insolvency proceedings or make any composition with his creditors or attempt to do so, or if any bribe, gratuity, gift, loan, perquisite, reward or advantage pecuniary or otherwise, shall either directly or indirectly, be given, promised or offered by the Bidder, or any of his servants or agent to any officer or person in the employ of the Employer in any way relating to his office or employment, or if any such officer or person shall become in any way directly or indirectly interested in the contract, the Employer shall have power to adopt any of the courses specified in Clause 3 hereof as he may deem best suited to the interest of the Employer and in the event of any of these courses being adopted the consequences specified in the said Clause 3 shall ensue.

Clause - 22 :: REASONABLE COMPENSATION ::

All sums payable by way of compensation under any of these conditions shall be considered as reasonable compensation to be applied to the use of the Employer without reference to the actual loss or damage sustained.

Clause - 23 :: APPROVAL FOR CHANGE IN CONSTITUTION ::

Where the Bidder is a partnership firm, the previous approval in writing of the Employer shall be obtained before any change is made in the constitution of the firm. Where the Bidder is an individual business concern such approval as aforesaid shall likewise be obtained before the Bidder enters into any partnership agreement where under the partnership firm would have the right to carry out the works hereby undertaken by the Bidder. If previous approval as aforesaid is not obtained, the contract shall be deemed to have been assigned in contravention of Clause 21 hereof and the same action may be taken, and the same consequences shall ensue as

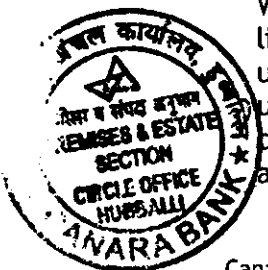

provided in the said Clause 21.

Clause - 24 :: DIRECTIONS AS TO WORK ::

All works to be executed under the contract shall be executed under the direction and subject to the approval in all respects of the Engineer-in-Charge/ Employer who shall be entitled to direct at what point or points and in what manner are to be commenced, and from time to time carried on.

Clause - 25 :: SETTLEMENT OF DISPUTES AND ARBITRATION ::

IV. It shall be accepted as an inseparable part of the contract that in matters regarding conditions & clauses of contract, quality of materials, workmanship, removal or rejection of improper work, interpretation of the drawings and specifications, measurements of materials and/or items of work, mode of procedure and carrying out of the work, the decision of the Employer which shall be given in writing, shall be final, conclusive and binding on the Bidder.

ii) (A) If the Bidder considers any work demanded of him to be outside the requirements of the contract, or considers any drawings record or decision given in writing by the Engineer-in-Charge on any matter in connection with or arising out of the contract or carrying out of work, to be unacceptable, he shall promptly within 15 days request the Accepting Authority in writing for written instruction or decision. Thereon, the Accepting Authority shall give his written instructions or decision within a period of two months from the receipt of the Bidder's letter.

(B) Upon receipt of such written instructions or decision the Bidder shall promptly proceed without delay to comply with such instructions or decisions. If the Accepting Authority fails to give his instructions or decision in writing within a period of two months after being requested or if the Bidder is dissatisfied with the instructions or decision of the Accepting Authority Employer, the Bidder may within 30 days appeal to the Appointing Authority who shall afford an opportunity to the Bidder to be heard and to offer evidence in support of his appeal and give his decision in writing within a period of Thirty (30) days from the receipt of the Bidder's request. If the Bidder is dissatisfied with the decision of the appointing authority, then the Bidder shall within a period of Thirty (30) days from receipt of the decision of the Appointing authority shall indicate his intention to refer the dispute to Arbitration, Failing which the said decision of the Appointing authority shall be final and conclusive and not referable to adjudication by the Arbitrator.

iii) All disputes or differences in respect of which decisions have not been final, binding and conclusive as above shall be referred for adjudication by the arbitration by a Sole Arbitrator appointed as follows:

Within Thirty (30) days of receipt of notice from any party to the contract for appointment of the Arbitrator the Appointing authority, in charge of the work (Schedule F) at the time of such appointment shall send to the Bidder a panel of three names of persons who shall not presently be connected with the work.

The Bidder shall within fifteen (15) days of receipt of this list select and communicate to the Appointing authority the name of one person from the list who shall then be appointed as the sole arbitrator by the Appointing authority.

If Bidder fails to communicate his selection of name of the person, within Fifteen (15) days as stipulated, the Appointing authority shall without delay select one person from the list and appoint him as Sole Arbitrator.

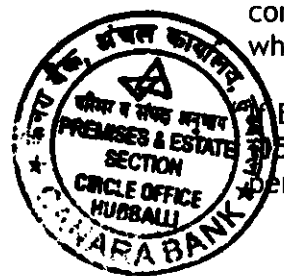

If the Appointing authority fails to send such a list within Thirty (30) days as stipulated, the Bidder shall send a similar list to the Appointing authority within fifteen (15) days. The Appointing authority shall then select one person from the list and appoint him as the Sole Arbitrator within Thirty (30) Days of the receipt of the list. If the Appointing authority fails to do so then the Bidder shall communicate to the Appointing authority the name of one person from the list who shall then be the Sole Arbitrator.

If the Arbitrator so appointed is unable or unwilling to act or resigns his appointment or vacates his office due to any reason whatsoever another sole Arbitrator shall be appointed in the manner aforesaid. Such person shall be entitled to proceed with the reference from the stage at which it was left by his predecessor.

iv) It is term of this contract that the party invoking arbitration shall give a list of disputes with amounts claimed in respect of each such dispute along with the notice for appointment of arbitrator and giving reference to the rejection by the Appointing authority of the appeal and a copy of his notice(s) of intention to refer the dispute to arbitration of such disputes as mentioned in Part (ii) above failing which the notice for appointment of the Arbitrator shall not be treated as notice for appointing the arbitrator.

v) It is also a term of this contract that no person other than a person appointed by Appointing authority, in charge of the work as aforesaid should act as arbitrator and if for any reason that is not possible, the matter shall not be referred to arbitration at all.

vi) It is also a term of the contract that if the Bidder does not make any demand for appointment of arbitration in respect of any claims in writing as aforesaid within 90 days of receiving the intimation from the Appointing authority that the final bill is ready for payment, the claim of the Bidder shall be deemed to have been waived and absolutely barred and the Employer shall be discharged and released of all liabilities under the contract in respect of these claims. No party shall be entitled to bring any claim to arbitration if the arbitrator has not been appointed before the expiry of sixty days after defect liability period.

vii) The arbitration shall be conducted in accordance with the provisions of the Indian Arbitration and Conciliation ACT 1996, or any statutory modification or re-enactment thereof and the rules made there under and for the time being in force shall apply to the arbitration proceeding under this clause.

viii) The Arbitrator may from time to time with the consent of the parties enlarge the time for making and publishing the award.

ix) It is also a term of this contract that the Arbitrator shall ad judicial on only such disputes as are referred to him by the appointing authority and give separate award against every dispute and claim referred to him and in all cases where the total amount of the claims by any party exceed the amounts specified in Schedule

F the arbitrator shall give reasons for the award separately for every dispute.

x) It is also a term of the contract that any fees, TA, DA and other charges are payable to the Arbitrator shall be paid by both the parties equally.

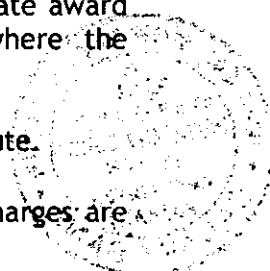
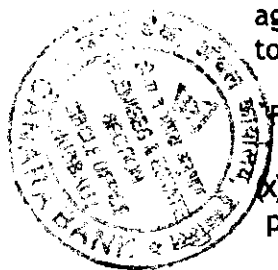

(xi) The venue of the arbitration shall be such a place as may be fixed by the Arbitrator in his sole discretion.

xi) It is also a term of the contract that the Arbitrator shall be deemed to have entered on the reference on the date of first hearing. The fees and charges of the Arbitrator shall, if required to be paid before the award is made and published, be paid half and half by each of the parties. The cost of the reference and of the award (including the fees, if any, of the Arbitrator) shall be in the discretion of the Arbitrator who may direct to and by whom and in what manner, such costs or any part thereof shall be paid and fix or settle the amount of costs to be so paid.

xii) The award of the Arbitrator shall be final and binding on both the parties.

Clause - 26:: INDEMNITY ::

The Bidder shall keep and hold the Employer indemnified and harmless from time to time and at all times against all actions, prosecutions proceedings, claims, suits, liabilities (including statutory liability), penalties, demands, charges, costs (including legal costs) and expenses, damages, losses and any other expenses which may be caused to or suffered by or made or taken against the Employer arising out of:

- i) The breach, default or non-performance of undertakings, warranties, covenants or obligations by the Bidder, non-compliance of safety rules, regulations, instructions by the Bidder and mishaps occurring at the site due to faulty work executed by the Bidder.
- ii) Any contravention or Non compliance with any applicable laws, regulations, rules, statutory or legal requirements by the Bidder. Further, the Bidder shall indemnify, protect and save the Employer against all claims, losses, costs, damages, expenses, action suits and other proceedings, resulting from infringement of any law pertaining to patent, trademarks, copyrights etc. or such other statutory infringements in respect of the services offered by the Bidder.

All Indemnities shall survive notwithstanding expiry or termination of the contract and Bidder shall continue to be liable under the indemnities.

There is no limit to claims made by the Employer / third parties in case of infringement of Intellectual property rights or for claims relating to the loss of damage to real property and tangible personal property and for bodily injury or death and in these cases the liability will be unlimited ”.

Indemnity format is enclosed as Annexure - 19. The same to be duly filled and submitted by the successful bidder in a non-judicial stamp paper of appropriate value.

Clause - 27:: ESTIMATE ::

When the estimate on which a tender is made includes lump sum in respect of parts of the work the Bidder may be entitled to payment in respect of the items of work involved or the part of the work in question at the same rates as are payable under this contract for such items, or if the part of the work in question is not, in the opinion of the Engineer-in-Charge capable of measurement, the Employer may at his discretion pay the lump-sum amount entered in the estimate, and the certificate in writing of the Employer shall be final and conclusive against the Bidder with regard to any sum or sums payable to him under the provisions of the clause.

Clause -28:: ACTION WHERE NO SPECIFICATIONS ARE SPECIFIED::



In the case of any class of work for which there is no such specifications as referred to in Clause 11, such work shall be carried out in accordance with the Bureau of Indian Standards Specifications. In case there are no such specifications in Bureau of Indian Standards, the work shall be carried out as per manufacturers' specifications, if not available then as per District Specifications. In case there are no such specifications as required above, the work shall be carried out in all respects in accordance with the instructions and requirements of the Engineer-in- Charge.

Clause - 29:: LIEN ::

(a) Whenever any claim or claims for payment of a sum of money arises out of or under the contract against the Bidder, the Engineer-in-Charge or the Employer shall be entitled to withhold and also have a lien to retain such sum or sums in whole or in part from the security, if any deposited by the Bidder and for the purpose aforesaid, the Engineer-in-Charge or the Employer shall be entitled to withhold the security deposit, if any, furnished as the case may be and also have a lien over the same pending finalization or adjudication of any such claim. In the event of the security being insufficient to cover the claimed amount or amounts or if no security has been taken from the Bidder, the Engineer-in-Charge or the Employer shall be entitled to withhold and have a lien to retain to the extent of such claimed amount or amounts referred to above, from any sum or sums found payable or which may at any time thereafter become payable to the Bidder under the same contract or any other contract with the Employer pending finalization or adjudication of any such claim.

(b) Any sum of money due and payable to the Bidder (including the security deposit returnable to him) under the contract may be withhold or retained by way of lien by the Engineer-in-Charge or the Employer or any other contracting person or persons through Engineer-in-Charge against any claim of the Engineer- in-Charge or the Employer or such person or persons in respect of payment of a sum of money arising out of or under any other contract made by the Bidder with the Engineer-in-Charge or the Employer or with such other person or persons.

(c) It is an agreed term of the contract that the sum of money or moneys so withheld or retained under the lien referred to above by the Engineer-in- Charge or the Employer will be kept withheld or retained as such by the Engineer-in-Charge or the Employer till the claim arising out of or under the contract is determined by the arbitrator (if the contracts governed by the arbitration clause) or by the competent court, as the case may be and that the Bidder will have no claim for interest or damages whatsoever on any account in respect of such withholding or retention under the lien referred to above and duly notified as such to the Bidder. For the purpose of this clause, where the Bidder is a partnership firm or a limited company, the Engineer-in-Charge or the Employer shall be entitled to withhold and also have a lien to retain towards such claimed amount or amounts in whole or in part from any sum found payable to any partner/limited company as the case may be, whether in his individual capacity or otherwise.

Clause -29 A:: RIGHT TO AUDIT/TECHNICAL EXAMINATION ::

The Employer shall have the right to cause an audit and technical examination of the works and the final bills of the Bidder including all supporting vouchers, abstract, etc., to be made even after payment of the final bill and if as a result of such audit and technical examination any sum is found to have been overpaid in respect of any work done by the Bidder under the contract or any work claimed to have been done by him under the contract and found not to have been executed, the Bidder shall be liable to refund the amount of over-payment and it shall be lawful for the Employer to recover the same from him in the manner prescribed in clause 29 or in any other



manner legally permissible and if it is found that the Bidder was paid less than what was due to him under the contract in respect of any work executed by him under it, the amount of such under payment shall be duly paid by the Employer to the Bidder, without any interest thereon; Provided that the Bidder shall not be entitled to payment of any sum paid short where such payment has been agreed upon between the Employer and Engineer-in-Charge on the one hand and the Bidder on the other under any term of the contract permitting payment for work after assessment by the Employer and Engineer-in-Charge.

Clause - 30:: CONTROLLED AREA LABOUR ::

THE Bidder shall not employ coal mining or controlled area labour falling under any category whatsoever on or in connection with the work or recruit labour from area within a radius of 32 km (20 miles) of the controlled area Subject as above the Bidder shall employ imported labour only i.e., depot imported labour or labour imported by Bidders from area, from which import is permitted. Where ceiling price for imported labour has been fixed by State or Regional Labour Committees not more than that ceiling price shall be paid to the labour by the Bidder.

The Bidder shall immediately remove any labourer who may be pointed out by the Engineer-in-Charge as being a coal mining or controlled area labourer. Failure to do so shall render the Bidder liable to pay to Government a sum calculated at the rate of Rs.10/- per day per labourer. The certificate of the Engineer-in-Charge about the number of coal mining or controlled area labourer and the number of days for which they worked shall be final and binding upon all parties to this contract.

The aforesaid stipulation in this clause is one in which the public are interested within the meaning of the exception in Section 74 of Indian Contract Act, 1872.

Any area which may be declared a 'controlled Area' by or with the approval of the Central Government.

Clause - 31 :: WATER SUPPLY

The Bidder(s) shall make his/their own arrangements for water required for the work and nothing extra will be paid for the same. This will be subject to the following conditions::

- (i) That the water used by the Bidder(s) shall be fit for construction purposes to the satisfaction of the Engineer-in-Charge.
- (ii) The Engineer-in-Charge shall make alternative arrangements for supply of water at the risk and cost of Bidder(s) if the arrangements made by the Bidder(s) for procurement of water is in the opinion of the Engineer-in-Charge, unsatisfactory.

Clause - 32 :: ALTERNATE WATER SUPPLY ::

(i) Where there is no piped water supply arrangement and the water is taken by the Bidder from the wells or hand pump constructed by the Employer, if any, charge at 1 % (one percent) of the Gross value of the work shall be recovered from the Bidder on that account. The Bidder shall, however, draw water at such hours of the day that it does not interfere with the normal use for which the hand pumps and wells are intended. He will also be responsible for all damage and abnormal repairs arising out of his use, the cost of which shall be recoverable from him. The Engineer-in-Charge shall be the final authority to determine the cost recoverable from the Bidder on this account and his decision shall be binding on the Bidder.

(ii) The Bidder shall be allowed to construct temporary wells or bore well in on employers land for taking water by pumping at his own cost, for construction purposes

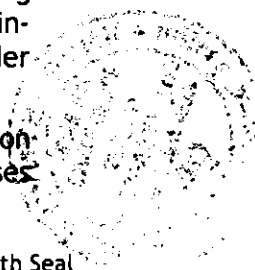
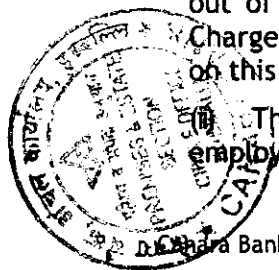

only after he has got permission of the Engineer-in-Charge in writing. No charges shall be recovered from the Bidder on this account, but the Bidder shall be required to provide necessary safety arrangements to avoid any accidents or damage to adjacent buildings, roads and caused due to construction and subsequent maintenance of the wells and shall restore the ground to its original condition after the wells are dismantled on completion of the work.

Clause - 33 :: TRUST ::

Notwithstanding anything contained to the contrary herein , where any material for the execution of the contract are procured with the assistance of the Employer either by issue from Employers stocks or purchase made under orders or permits or licenses issued by the Employer or with the assistance of the Employer the Bidder shall hold the said materials economically and solely for the purpose of the contract and not dispose of them without the written permission of the Employer and return, if required by the Engineer-in-Charge, all surplus or unserviceable materials that may be left with him after the completion of the contract or at its termination for any reason whatsoever on being paid or credited such price as the Engineer-in-Charge shall determine having due regard to the condition of the materials. The price allowed to the Bidder however shall not exceed the amount charged to him excluding the element of storage charges. The decision of the Engineer-in-Charge shall be final and conclusive. In the event of breach of the aforesaid condition the Bidder shall in addition to throwing himself open to action for contravention of the terms of the licence or permit and/or for criminal breach of trust, be liable to the Employer for all moneys, advantages or profits resulting or which in the usual course would have resulted to him by reason of such breach.

Clause - 34 :: ARRANGEMENTS OF MACHINERY EQUIPMENT ::

The Bidder shall arrange at his own expense all tools, plant, machinery and equipment required for execution of the work.

Clause - 35 :: UNDERTAKING BY THE BIDDER & DLP::

(i) The Bidder undertakes to make arrangement for the supervision of the work by the firm supplying the tar or bitumen used.

(ii) The Bidder shall collect the total quantity of tar or bitumen required for the work as per standard formula, before the process of painting is started and shall hypothecated it to the Employer. If any bitumen or tar remains unused on completion of the work on account of lesser use of materials in actual execution for reasons other than authorized changes of specification and abandonment of portion of work, a corresponding deduction equivalent to the cost of unused materials as determined by the Engineer-in-Charge shall be made and the material returned to the Bidders. Although the materials are hypothecated to the Employer the Bidder undertakes the responsibility for their proper watch, safe custody and protection against all risks. The materials shall not be removed from site of work without the consent of the Employer in writing.

(iii) The Bidder shall be responsible for rectifying defects noticed in the works within a year (i.e. one year) from the date of completion of the work. For specialized works the guarantee shall be for 10years.

Clause - 36:: BIDDERS SUPERINTENDENCE, SUPERVISION, TECHNICAL STAFF & EMPLOYEE ::

(i) The Bidder shall provide all necessary superintendence during execution of the work and as long thereafter as may be necessary for proper fulfilling of the obligations under the contract.



The Bidder shall immediately after receiving letter of acceptance of the tender and before commencement of the work, intimate in writing to the Employer the name, qualifications, experience, age, address and other particulars along with certificates, of the principal technical representative to be in charge of the work. Such qualifications and experience shall not be lower than specified in Schedule F. The Employer shall within 30 days of receipt of such communication intimate in writing his approval or otherwise of such a representative to the Bidder. Any such approval may at any time be withdrawn and in case of such withdrawal the Bidder shall appoint another such representative according to the provisions of this clause. Decision of the tender accepting authority shall be final and binding on the Bidder in this respect. The work shall be started only after such a principal technical representative is appointed.

If the Bidder (or any partner in case of firm/company) who himself has such qualifications, it will not be necessary for the said Bidder to appoint such a principal technical representative but the Bidder shall disengage and appoint a responsible agent to represent him to be present at the work whenever the Bidder is not in a position to be so present. All the provision applicable to the Principal Technical representative under this clause will also be applicable in the case of Bidder or his responsible agent. The Principal Technical representative and/or the Bidder shall on receiving reasonable notice from the Engineer-in-Charge or his designated representative(s) in charge of the work in writing or in person or otherwise, present himself to the Engineer-in-Charge and/or at the site of work, as required, to take instructions.

Instructions given to the principal technical representative or the responsible agent shall be deemed to have the same force as if these have been given to the Bidder. The Principal Technical Representative and/or the Bidder or his responsible authorized agent shall be actually available at site at least on two working days every week, these days shall be determined in consultation with the Engineer-in-Charge as well as fully during important stages of execution of work, during recording of measurement of works and whenever so required by the Engineer-in-Charge by a notice as aforesaid and shall also note down instructions conveyed by the Engineer-in-Charge or his designated representative in the site order book and shall affix his signature in token of noting down the instructions and in token of acceptance of measurements. There shall be no objection if the representative/agent looks after more than one work and not more than three works in the same station provided these details are disclosed to the Engineer-in-Charge and he shall be satisfied that the provisions and the purpose of this clause are fulfilled satisfactorily.

If the Engineer-in-Charge, whose decision in this respect is final and binding on the Bidder is convinced that no such technical representative or agent is effectively appointed or is effectively attending or fulfilling the provision of this clause, a recovery shall be effected from the Bidder as specified in Schedule 'F' and the of the Engineer-in-Charge as recorded in the site order book and measurements recorded in Measurement Books shall be final and binding on the Bidder.

Further if the Bidder fails to appoint a suitable technical representative or responsible agent and if such appointed person(s) or not effectively present or do not discharge their responsibilities satisfactorily, the Engineer-in-Charge shall have full powers to suspend the execution of the work until such date as a suitable agent is appointed and the Bidder shall be held responsible for the delay so caused to the work. Bidder shall submit a certificate of employment of the technical representative/responsible agent with every on account bill/final bill and shall produce evidence if at any time so required by the Engineer-in-Charge.

The Bidder shall provide and employ on the site only such technical assistants as



are skilled and experienced in their respective fields and such foremen and Supervisory staff as are competent to give proper supervision to the work.

The Bidder shall provide and employ skilled, semi-skilled and unskilled labour as is necessary for proper and timely execution of the work.

The Engineer-in-Charge shall be at liberty to object to and require the Bidder to remove from the works any person who in his opinion misconduct himself, or is incompetent or negligent in the performance of his duties or whose employment is otherwise considered by the Engineer-in-Charge to be undesirable. Such person shall not be employed again at works site without the written permission of the Engineer-in-Charge and the persons so removed shall be replaced as soon as possible by competent substitutes.

Clause - 37:: TAXES ::

(i) Entry Tax, Cess, Profession tax, turnover tax or any other tax on materials and/or completed works unless otherwise specifically excluded in respect of this contract shall be payable by the Bidder and Employer shall not entertain any claim whatsoever in this respect other than normal payment for completed item of work at the accepted rate.

(ii) Goods & Services Taxes (Item rates) on works contract on finished works wherever applicable shall be paid by Bank as per extant rules.

(iii) ----- N.A -----

V. If pursuant to or under any law, notification or order any royalty, cess, fee or the like becomes payable by the Employer and does not at any time become payable by the Bidder to the State Government and/or the local authorities in respect of any material used by the Bidder in the works then in such a case, it shall be lawful to the Employer and the Employer will have the right and be entitled to recover the amount paid in the circumstances as aforesaid from dues of the Bidder.

Clause - 38:: TENDERED RATES ::

(i) All tendered rates shall be inclusive of all taxes, royalties, cess and levies etc as stated in clause-37.I and payable under respective statutes. However, pursuant to the Constitution (Forty Sixth amendment) Act, 1982, if any further new tax royalties cess or levy is imposed by Statute, after the date of receipt of tenders, and the Bidder there upon necessarily and properly pays such taxes/levies the Bidder shall be reimbursed the amount so paid, provided such payments, if any, is not, in the opinion of the Employer (whose decision shall be final and binding on the Bidder) attributable to delay in execution of work within the control of the Bidder.

(ii) The Bidder shall keep necessary books of accounts and other documents for the purpose of this condition as may be necessary and shall allow inspection of the same by a duly authorized representative of the Employer and/or the Engineer-in-Charge and further shall furnish such other information/document as the Engineer-in-Charge may require from time to time.

(iii) The Bidder shall, within a period of 30 days of the imposition of any such further tax royalties, cess, or levy, pursuant to the constitution (Forty sixth Amendment) Act,

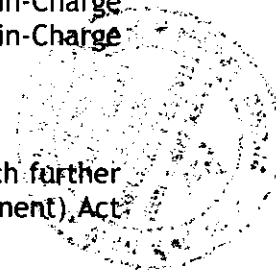
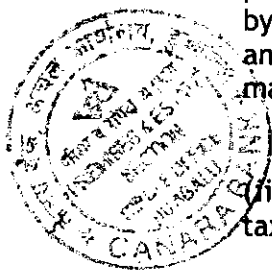

1982, give a written notice thereof to the Employer and Engineer-in-Charge that the same is given pursuant to this condition, together with all necessary information relating thereto.

Clause - 39:: DEATH ::

Without prejudice to any of the rights or remedies under this contract if the Bidder dies, the Employer shall have the option of terminating the contract without compensation to the Bidder.

Clause - 40:: RELATIVES ::

The Bidder shall not be permitted to tender for works in the Circle office of the Canara Bank (responsible for award of execution of contracts) in which his near relative is posted as an officer in any capacity between the grades of the General Manager and Manager(both inclusive) of premises and estate department. He shall also intimate the names of persons as per Annexure 05 who are working with him in any capacity or are subsequently employed by him and who are near relatives to any Officer in the Canara Bank or the Engineer in Charge employed by the Canara Bank for the work. Any breach of this condition by the Bidder would render him liable to be removed from the approved list of Bidders of the Employer.

Note::-By the term "near relatives" is meant wife, husband, parents and grandparents, children and grand children, brothers and sisters, direct uncles and aunts and first cousins.

Clause - 41:: EX-EMPLOYEES ::

No Engineer or other officer employed in the Canara Bank shall work as a Bidder or employee of a Bidder for a period of two years after his retirement from the Bank's service without the previous permission of the Employer. This contract is liable to be canceled if either the Bidder or any of

his employees is found at any time to be such person who had not obtained the permission of the Employer as aforesaid, before submission of the tender or engagement in the Bidders' service, as the case may be. Names of such persons employed by the Bidder shall be informed as per Annexure16.

Clause -42:: METHOD TO CALCULATE CONSUMPTION OF MATERIALS ::

(i) After completion of the work and also at any intermediate stage in the event of non-reconciliation of materials issued, consumed and in balance, theoretical quantity of materials issued by the Employer or the material brought by the Bidder for use in the work shall be calculated on the basis and method given hereunder:-

- a) Quantity of cement and Bitumen shall be calculated on the basis of quantity of cement and Bitumen required for different items of works shown in the Schedule of Rates mentioned in Schedule 'F'. In case any item is executed for which standard constants for the consumption of cement or bitumen are not available in the above mentioned schedule/statement or cannot be derived from the same shall be calculated on the basis of standard formula to be laid down by the Employer or Engineer-in-Charge.

Theoretical quantity of steel reinforcement or structural steel sections shall be taken as the quantity required as per design or as authorized by Engineer-in-Charge.



c) For any other material as per actual requirement and as approved by the Engineer-in-Charge.

(ii) Such theoretical consumption statements shall be prepared at every bill stage for the consumption of cement, steel (diameter wise and section wise) Bitumen and any other material specified by the Engineer-in-Charge in the same method and manner as in sub Para (i) above even if such materials are procured by the Bidder and not issued by the Employer.

(iii) Over the theoretical quantities of materials so computed a variation shall be allowed as specified in Schedule 'F'. The difference in the net quantities of material actually issued to or procured by the Bidder and the theoretical quantities including such authorized variation, if not returned by the Bidder (for materials issued by the Employer) or if not fully reconciled to the satisfaction of the Engineer-in-Charge shall be recovered at the rates specified in Schedule 'F', without prejudice to the provision of the relevant conditions regarding return of materials governing the contract. In the case of materials procured by the Bidder the cost of such material used less than the theoretical requirement shall be recovered at full market Rate plus the cartage cost to site.

(iv) The said action under this clause is without prejudice to the right of the Employer to take action against the Bidder under any other conditions of the contract for not doing the work according to the prescribed specifications.

Clause - 43::

The work (whether fully constructed or not) and all materials, machines, tools and plants, scaffolding, temporary buildings and other things connected therewith shall be at the risk of the Bidder until the work has been delivered to the Employer and a certificate from Engineer in charge to that effect obtained. In the event of the work or any materials properly brought to the site for incorporation in the work being damaged or destroyed in consequence of hostilities or warlike operation, the Bidder shall when ordered (in writing) by the Engineer-in-Charge to remove any debris from the site, collect and properly stack or remove in store all serviceable materials salvaged from the damaged work and shall be paid at the contract rates in accordance with the provision of this agreement for the work of clearing the site of debris, stacking or removal of serviceable material and for reconstruction of all works ordered by the Engineer-in-Charge, such payments being in addition to compensation upto the value of the work originally executed before being damaged or destroyed and not paid for. In case of works damaged or destroyed but not already measured and paid for, the compensation shall be assessed by the Engineer-in-Charge upto Rs.5,000/- and by the Employer concerned for a higher amount. The Bidder shall be paid for the damages/destruction suffered and for the restoring the material at the rate based on analysis of rates tendered for in accordance with the provision of the contract. The certificate of the Engineer-in-Charge regarding the quality and quantity of materials and the purpose for which they were collected shall be final and binding on the Bidder.

Provided always that no compensation shall be payable for any loss in consequence of hostilities or war-like operations (a) unless the Bidder had taken all such precautions against air raid as are deemed necessary by the Engineer-in-Charge (b) for any material etc. not on the site of the work or for any tools, plant, machinery, scaffolding, temporary building and other things not intended for the work.

In the event of the Bidder having to carry out reconstruction as aforesaid, he shall be allowed such extension of time for its completion as is considered reasonable by the



employer.

Clause - 44 :: APPRENTICES ::

THE Bidder shall comply with the provisions of the Apprentices Act, 1961 and the rules and orders issued there under from time to time. The Bidder shall also be liable for any pecuniary liability arising on account of any violation by him of the provisions of the said Act.

Clause - 45 :: CLEARANCE CERTIFICATE ::

Security Deposit of the work shall not be refunded till the Bidder produces a clearance certificate from the Labour Officer. As soon as the work is virtually complete the Bidder shall apply for the clearance certificate to the Labour Officer under intimation to the Engineer-in-Charge. The Engineer-in-Charge, on receipt of the said communication, write to the Labour Officer to this effect till six months after the date of completion, it will be deemed to have received the clearance certificate and the Security Deposit will be released if otherwise due.

Clause - 46:: DAMAGES & INSURANCE

THE Bidder shall be responsible for all injury to the work or workmen to persons, animals or things and for all damages to the structural and/or decorative part of property which may arise from the operations or neglect of himself or of any sub-Bidder or of any of his or a sub-Bidders employees, whether such injury or damage arise from carelessness, accident or any other cause whatsoever in any way connected with the carrying out of this contract. The clause shall be held to include interalia, any damages to buildings whether immediately adjacent or otherwise, and any damage to roads, streets, footpaths or ways as well as damages caused to the buildings and the works forming the subject if this contract by rain, wind or other inclemency of the weather. The Bidder shall indemnify the employer and hold harmless in respect of all and any expenses arising from such injury or damages to persons or property as aforesaid and also in respect of any claim made in respect of injury or damage under any acts of compensation or damage consequent upon such claim.

THE Bidder shall reinstate all damage of every sort mentioned in this clause, so as to deliver the whole of the contract works complete and perfect in every respect and so as to make good or otherwise satisfy all claims for damages to the property or third parties. The Bidder shall affect the insurance necessary and indemnify the employer entirely from all responsibility in this respect. The insurance must be placed with a company approved by the employer and must be effected jointly in the name of the Bidder and the employer and the policy lodged with the latter. The scope of insurance is to include loss or damage to the work and workmen due to carelessness, accident including fire, earthquake, floods, etc., damage or loss to the contract itself till this is make over a complete state. Insurance is compulsory and must be affected from the very initial stage. The Bidder shall also be responsible for anything which may be excluded from damage to any property arising out of incidents, negligence or defective carrying out of this contract.

THE employer shall be at liberty and is hereby empowered to deduct the amount of any damages, compensations, costs, charges and expenses arising or occurring from or in respect of any such claim or damages from any sums due or to become due to the Bidder.

Clause - 47:: INSURANCE ::

The Bidder shall insure the works and keep them insured until the virtual completion of the contract against loss or damages by fire and/or earthquake, flood. The insurance must be placed with a company approved by the Employer, in the joint names of the employer and the Bidder for such amount and for any further sum if called to do so by the employer and lodge receipts of premiums paid with the employer within 21 days from the date of issue of letter of acceptance unless otherwise instructed. In default of the contract insuring as

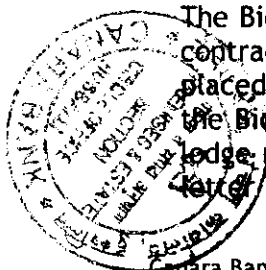

provided above, the employer on his behalf may so insure and deduct the premiums paid from any money due or which may become due to the Bidder. The Bidder shall as soon as the claim under the policy is settled or the work reinstated by the insurance company should they elect to do so, proceed with due diligence will the completion of the works in the same manner as though the damages has not occurred and in all respects under the conditions of the contract. The Bidder in case of rebuilding or reinstatement after fire shall

be entitled to extension of time for completion as the employer/architect may deem fit.

Clause - 48:: ABNORMALLY HIGH AND LOW RATED ITEMS ::

For item rate tenders if, the rates quoted by the lowest bidder for certain items of the Bill of Quantities of the tender are found to be abnormally high or low in comparison to the market rate analysis of the item done by the Architects/Bank and or in comparison to Architect/Bank's method of working out market rate justification for the items, the same shall be governed as under in order to avoid financial loss to the Bank in the event of default of Bidders.

- i) For abnormally high rated items (AHR), the progressive payment shall be 80% (eighty percent) of the payment due to the Bidder against execution of the AHR item. The balance withheld 20% payment shall be released after 75% of total value of the original contract is complete in financial terms or this 20% withheld payment can be released to the Bidder on submission of an unconditional bank guarantee of equivalent amount in the proforma of Bank. Further deviation limit for AHR items shall be nil on plus side and Bank reserves the right to restrict, substitute or not execute the AHR items during execution. The decision of the Architect/Bank's Engineer in this regard shall be final and binding on the Bidder.
- ii) For abnormally low rated (ALR) items the Bidder shall submit Bank Guarantee of difference in total of amount of ALR item(s) and the total amount of corresponding items at market rate of the Architect/Bank. This bank guarantee shall be valid till completion of the project. In exceptional circumstances, the amount of Bank Guarantees (BG) may be reduced or BG released earlier than completion period if, in view of Architect/Bank's Engineer, all ALR items as provided in the contract are executed as per terms of contract and/or not required to be executed.

Notwithstanding what is contained in Para i) & ii) above, the provisions of Para i) and ii) shall not be applicable on tenders invited on percentage rate basis.

The decision of the Architects on identification/ marking of AHR and ALR item is final and binding on the Bidder. In case the Bidder do not agree for furnishing of Bank Guarantee as above towards ALR items, at the time of award of works, the EMD/Performance guarantee of the Bidder shall be forfeited and decision of Architect in this regard shall be final and binding on the Bidder.

◆◆◆◆◆◆◆◆



SPECIAL CONDITIONS**1 Scope:**

1.1 The works to be governed by this contract shall cover Interior furnishing works of Circle office, Hubballi as specified in the schedule A & E along with all services, including all materials, labour, delivery and transportation up to destination, safe custody at site, insurance, erection, testing and commissioning of the entire works.

1.2 The Contractor shall obtain all the relevant permissions from the local governing departments (wherever applicable) and shall bear the incidental expenses for the same. Any statutory payments, deposits, fee made to the appropriate authorities for permanent services connections shall be reimbursed by the Employer provided the receipts/ deposits are in the name of the CanaraBank.

1.3 The Contractor shall also be responsible to obtain all the Temporary service connections i.e. Electricity Power, Water and Sewerage (wherever applicable) connections and shall bear any incidental expenses, fees, deposits, monthly consumption charges required for the construction work.

1.4 The works to be undertaken by the Bidder shall inter alia include the following:

- i. Preparation of detailed SHOP drawings and AS BUILT drawings wherever applicable.
- ii. Obtaining of Statutory permissions where-ever applicable and required.
- iii. Pre-commissioning tests as per relevant standard specifications, code of practice, Acts and Rules wherever required.
- iv. Warranty obligation for the equipments and/or fittings/fixtures supplied by the Bidder.

1.5 All the hidden items such as reinforcement steel, electrical conduits, water supply lines, drainage pipes, conduits, sewers etc. are to be properly tested as per the design conditions before covering and their measurements in measurement book duly test checked shall be deposited with Engineer in charge or his authorized representative, prior to hiding these items.

2 Precautionary measures:

2.1 Temporary barricading shall be provided at site by the Bidder at his own cost. The barricading physically define the boundaries of the plot for restricted entry to only those involved in the work and also to prevent any accident and also not causing any inconvenience to the traffic. Any further barricading as required for basement excavation at Site shall be provided by the Bidder at his own cost. The barricading should be made in suitable size, shapes and number as directed by Engineer-in-charge without any extra cost. It shall be dismantled and taken away by the Bidder after completion of the work at his own cost with the approval of Engineer-in- charge.

2.2 Bidder shall take all precautionary measures to avoid any damage to adjoining property. All necessary arrangement shall be made at his own cost.

2.3 The Bidder shall take all precautions to prevent his workmen and employees from removing and damaging any Flora (tree/plant/vegetation) from the site.

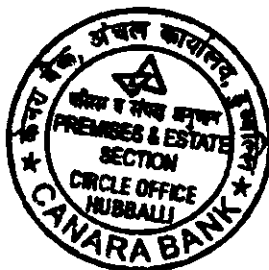

2.4 The Bidder shall take all precautions to avoid accidents by exhibiting necessary caution boards day and night, speed limit boards, red flags, red lights and providing barriers. He shall be responsible for all damages and accidents caused to work due to negligence on his part. No hindrances shall be caused to traffic, during the execution of the work. In case of any accident of the labourers / contractual staff, the entire responsibility will rest on the Bidder and any compensation under such circumstances, if becomes payable, shall be entirely borne by the Bidder.

2.5 The Bidder, his authorized representative, workmen etc. shall strictly observe orders pertaining to fire precautions prevailing in the area.

2.6 The Bidder shall take all necessary precautions to prevent any nuisance or inconvenience to the owners, tenants or occupants of the adjacent properties and to the public in general. The Bidder shall take all care, as not to damage any other adjacent property or other services running adjacent to the plot. If any damage is done, the same shall be made good by the Bidder at his own cost and to the entire satisfaction of the Engineer-in-Charge. The Bidder shall use such methodology and equipments for execution of the work, so as to cause minimum environmental pollution of any kind during construction, to have minimum construction time and minimum inconvenience to road users and to the occupants of the buildings on the adjacent plot and public in general, etc. He shall make good at his own cost and to the entire satisfaction of the Engineer in Charge any damage to roads, paths, cross drainage works or public or private property whatsoever caused, due to the execution of the work or by traffic brought thereon, by the Bidder. Further, the Bidder shall take all precautions to prevent any pollution of streams and waterways. All waste or superfluous materials shall be carted away by the Bidder, entirely to the satisfaction of the Engineer-in-Charge. Utmost care shall be taken to keep the noise level to the barest minimum so that no disturbance as far as possible is caused to the occupants / users of adjoining buildings. No claim what so ever on account of site constraints mentioned above or any other site constraints not specifically stated here, shall be entertained from the Bidder. Therefore, the Bidders are advised to visit site and get first hand information of site constraints. Accordingly, they should quote their tenders. Nothing extra shall be payable on this account.

3 General cleanliness of the site and Stacking & Storage of Materials:

3.1 The site of work shall be always kept clean in general strictly adhering to approved job layout/specifications. The Bidder shall take all care to prevent any water-logging at site. The waste water shall not be allowed to be collected at site. It may be directly pumped into the public drainage system with prior approval of the concerned authorities. For discharge into public drainage system, necessary permission shall be obtained from relevant authorities after paying the necessary charges, if any, directly to the authorities. The work shall be carried out in such a way that the area is kept clean and tidy. All the fees/charges in this regard shall be borne by the Bidder. Nothing extra shall be payable on this account.

3.2 The Bidder shall take instructions from the Engineer-in-Charge regarding collection and stacking of materials at any place. No excavated earth or building rubbish shall be stacked on areas where other buildings, roads, compound wall, services etc are to be constructed. The stacking shall be done as per stacking plan. However, if any change is required, the same shall be done with the



approval of Engineer-in-Charge.

3.3 For construction works which are likely to generate malba / rubbish, Bidder shall dispose of malba, rubbish & other unserviceable materials and wastes at his own cost to the dumping ground notified by local authorities and under no circumstances these shall be stacked / dumped even temporarily, outside the construction premises.

3.4 The Bidder shall not stack building material / malba on the road or on the land owned by any other authority, as the case may be. In case, the Bidder is found stacking the building material / malba as stated above, he shall be liable to pay the stacking charges as may be levied by local body or authority and also to face penal action as per the rules, regulations and bye-laws of the said body or authority. The Engineer-in-Charge shall be at liberty to recover the sums due but not paid to the concerned authorities on the above counts from any sums due to the Bidder including amount of the Security Deposit or Retention Money in respect of this contract or any other contract.

3.5 The Bidder shall construct suitable go downs, yard at the site of work for storing all other materials so as to be safe against damage by sun, rain, damages, fire, theft etc. at his own cost and also employ necessary watch and ward establishment for the purpose at his cost.

4. Laboratory Equipment:

41 The Bidder shall provide at his own cost suitable measuring tapes, weighing, surveying and leveling and measuring arrangements as may be necessary at site for checking. All such equipments shall be got calibrated in advance from laboratory, approved by the Engineer-in-Charge. Nothing extra shall be payable on this account. Minimum equipments as required for field tests shall be provided at site without any extra cost to the Employer.

5. Setting Out of works

51 The Bidder shall establish, maintain and assume responsibility for grades, lines, levels and bench marks. Bidder shall report any errors or inconsistencies regarding grades, lines, levels, dimensions to the Engineer-in-Charge before commencing work. Commencement of work shall be regarded as the Bidder's acceptance of such grades, lines, levels and dimensions and no claim shall be entertained at a later date for any errors found.

52 If at any time, any error in the respect of setting out appears during the progress of the work, the Bidder shall, at his own expense rectify such error if so required, to the satisfaction of the Engineer-in-Charge.

53

a) The Bidder shall provide, protect and maintain temporary / permanent benchmarks at the site of work throughout the execution of the work. These bench marks shall be got checked by the Engineer-in-Charge or his authorized representatives. The work at different stages shall be checked with reference to bench marks maintained for the said purpose. All such reference points shall be in relation to the levels and locations, given in the Architectural and plumbing drawings. Nothing extra shall be payable on this



account.

- b) The approval by the Engineer-in-Charge, of the setting out by the Bidder, shall not relieve the Bidder of any of his responsibilities and obligation to rectify the errors/defects, if any, which may be found at any stage during the progress of the work or after the completion of the work.

54 The Bidder shall be entirely and exclusively responsible for the horizontal, vertical and other alignments, the level and correctness of every part of the work and shall rectify effectively any errors or imperfections therein. Such rectifications shall be carried out by the Bidder at his own cost to the instructions and satisfaction of the Engineer-in-charge.

55 The Bidder shall carry out survey of the work area, at his own cost, setting out the layout of building in consultation with the Engineer-in-Charge & proceed further. Any discrepancy between the architectural drawings and actual layout at site shall be brought to the notice of the Engineer-in-charge. It shall be responsibility of the Bidder to ensure correct setting out of alignment. Survey instruments only shall be used for layout, fixing boundaries, and centre lines, etc. including theodolites. Nothing extra shall be payable on this account.

6. Architectural, structural and integrated service drawings:

6.1 Although tender drawings are made available with the Tender, the working & detailed architectural drawings and structural drawings shall be issued as and when required according to the programme chart submitted by the Bidder. It is the duty of the Bidder to intimate the requirement

of drawings reasonably well in advance and no hindrance shall be allowed on this account.

6.2 The work shall be carried out in accordance with the Architectural drawings and Structural drawings, to be issued from time to time, by the Engineer-in-Charge. Before commencement of any item of work, the Bidder shall correlate all the relevant architectural and structural drawings issued for the work, nomenclature of items, specifications etc. and satisfy himself that the information available there from is complete and unambiguous. The figures & the written dimensions of the drawing shall supersede the measurement by scale. The discrepancy, if any, shall be brought to the notice of the Engineer-in-Charge for immediate decision before execution of the work. The Bidder alone shall be responsible for any loss or damage occurring by the commencement of work on the basis of any erroneous and/ or incomplete information and no claim, whatsoever shall be entertained on this account. The delay caused on account of non- timely action by the Bidder in resolution of the differences whatsoever shall not be considered as valid ground for extension of time unless otherwise accepted by Engineer in charge.

6.3 The information and site data shown in the drawings and mentioned herein and also elsewhere in the tender documents are being furnished for general information and guidance only. The Engineer-in Charge/ Employer shall not bear responsibility for lack of such knowledge and also the consequences thereof. The Engineer-in-charge/ Employer in no case shall be held responsible for the accuracy thereof or any interpretation/ or conclusions drawn there from by the Bidder.

6.4 Before taking up the work, the Bidder shall be provided with working drawings for various civil and electrical services showing details of lay out plan



including sectional elevations and the Bidder shall plan and mobilize his resources as per the working drawings and as per the site conditions to facilitate convenient execution, installation as well as maintenance of these services. Nothing extra shall be payable on this account.

7. Scaffolding & Staging:

7.1 Wherever required for the execution of work, all the scaffolding shall be provided and suitably fixed, by the Bidder. The scaffolding shall be provided strictly with steel double scaffolding system, suitably braced for stability, with all the accessories, gangways, etc with adjustable suitable working platforms to access the areas with ease for working and inspection. Single scaffolding system is strictly prohibited and shall invite necessary action. It shall be designed to take all incidental loads. It should cater to the safety features for workmen. Nothing extra shall be payable on this account. It shall be ensured that no damage is caused to any structure due to the scaffolding.

8. Procurement of materials and Basic rate:

8.1 All material shall only be brought at site as per program finalized with the Engineer-in-Charge. Any pre-delivery of the material not required for immediate consumption shall not be accepted and thus not paid for.

8.2 The Bidder shall procure the required materials in advance so that there is sufficient time for testing of the materials and approval of the same before use in the work.

8.3 The Base price of materials eligible for cost adjustment are mentioned Annexure-18, the Bidder shall provide the materials accordingly, if the rate of the material selected by Bank is higher / lower than the above basic rate proportionate cost adjustment shall be made.

8.4 Base price shall be the actual price quoted by the authorized stockiest/wholesalers/ showroom including excise duty and excluding cess, octroi, GST and all other duties levied by the statutory / local authority and also excluding loading, unloading and carriage/ transportation cost to the site of work, overheads, storage charges at site.

9. Quoted Rates and other conditions for payment: The rates quoted by the Bidder for the descriptions given in the Schedule of quantities (SOQ) are deemed to be inclusive of the following apart from other inclusions elsewhere stipulated in these documents:

9.1 Site clearance, setting out work, profile, establishment of reference bench mark(s), taking spot levels, construction of all safety and protection devices, barriers, barricading, signage, labour safety, welfare, preparatory works, working during monsoon, working at all depths, height, lead, lift and location etc until / unless specified otherwise, and any other incidental Works required to complete this work. Nothing extra shall be payable on this account.

9.2 For works below ground level the Bidder shall keep that area free from water. If dewatering or bailing out of water is required the Bidder shall do it and nothing extra shall be paid except otherwise provided in the items of Schedule of quantities.



9.3 Any legal or financial implications resulting out of disposal of earth shall be sole responsibility of the Bidder. Nothing extra over the schedule shall be paid on this account.

9.4 All labour, material, tools and plants, temporary water, sewerage, electricity connection charges & works and other inputs involved/ required in the execution of the item.

9.5 Conducting Tests materials and works wherever stipulated

9.6 Any cement slurry added over base surface (or) for continuation of concreting for better bond is deemed to have been built in the items.

9.7 For completing the work in time, the Bidder might be required to work in two or more shifts (including night shifts). No claim whatsoever shall be entertained on this account, not with-standing the fact that the Bidder may have to pay extra amounts for any reason, to the labourers and other staff engaged directly or indirectly on the work according to the provisions of the labour and other statutory bodies regulations and the agreement entered upon by the Bidder with them.

9.8 The Bidder shall arrange to give all notices as required by any statutory / regulatory authority and obtain all requisite licenses wherever required and shall pay to such authority all the fees that is required to be paid for the execution of work. Nothing extra shall be payable on these accounts.

9.9 All ancillary and incidental facilities required for execution of work like labour camp, stores, fabrication yard, offices for Bidder, watch and ward, temporary ramp required to be made for working at the basement level, temporary structure for plants and machineries, water storage tanks, installation and consumption charges of temporary electricity, telephone, water etc. required for execution of the work, liaison with municipal / statutory authorities etc., protection works, barricading, testing facilities / laboratory at site of work, facilities for all field tests and for taking samples etc. during execution or any other activity which is necessary (for execution of work and as directed by Engineer-in Charge), shall be deemed to be included in rates quoted by the Bidder for various items in the Schedule of quantities. Nothing extra shall be payable on these accounts.

9.10 Final testing of the installation:

The Bidder shall demonstrate trouble free functioning of all the Plumbing, sanitary, electrical and E & M installations and services. The Engineer-in-Charge or his authorized representatives shall carry out final inspection of these various Plumbing, sanitary, electrical and E & M services and installations. Any defect(s) noticed during demonstration shall be rectified by the Bidder at his own cost to the entire satisfaction of the Engineer-in-Charge. Nothing extra shall be payable on this account.

9.11 Contributions towards the EPF & ESI for the labour, employees engaged by the Bidder wherever applicable shall be paid by the Bidder, Nothing extra shall be payable on this account.

10. Local laws:



1.1 The Bidder shall keep himself fully informed of all acts and laws of the Central & State Governments, all orders, decrees of statutory bodies, tribunals having any jurisdiction or authority, which in any manner may affect those engaged or employed and anything related to carrying out the work. All the rules & regulations and bye-laws laid down by Collector / Municipal authorities etc. and any other statutory bodies shall be adhered to, by the Bidder, during the execution of work. The Bidder shall also adhere to all traffic restrictions notified by the local authorities.

1.2 The Bidder shall ensure that applicable permits mandated by the local bodies and in case warranted for this work are obtained as required under the Applicable Laws.

1.3 The building work shall be carried out in the manner complying in all respects with the requirements of relevant bye-laws of the local body and sanctioned plans under the jurisdiction of which the work is to be executed or as directed by the Engineer-in-Charge and nothing extra shall be paid on this account.

11. Water Supply & Sanitary Installations & Testing:

The Bidder shall give performance test of the entire installation(s) as per the CPWD standing specifications before the work is finally accepted and nothing extra whatsoever shall be payable to the Bidder for the test.

12. Recording of Hindrances:-

121 Whenever any hindrance whether on part of Employer or on part of Bidder, comes to the notice of the Engineer in charge, the Bidder should at once make a note of such hindrance in the register kept at site, and immediately make a report to the Engineer in charge within a week.

122 Each hindrance should be entered in the Hindrance Register, (as per Annexure 13) which should be authenticated by the Engineer In charge and Bidder. The Employer shall review the Hindrance Register at least once in a month.

123 The hindrances on part of Bidder are also to be entered in the Hindrance Register.

124 The hindrance register shall be submitted at the time of payment of each Running Account Bill.

13. Progress and monitoring of work:

13.1 The Bidder shall submit the progress report for the work done during previous month to the Engineer-in charge on or before 5th day of each month. The progress report shall contain the following, apart from whatever else may be required as specified:-

(i) Construction schedule of the various components of the work through a bar chart for the next three months (or as may be specified), showing the inter milestones, targeted tasks and up to date progress. At least 3 digital photographs showing all the parts of the work in various stages during construction/repairs/restoration/concealed works in soft and hard copy have to be submitted in every monthly progress report.

Progress chart of the various components of the work that are planned and achieved, for the month as well as cumulative up to the month, with reason for

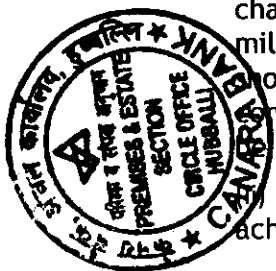

deviations, if any in a tabular format.

(iii) The Bidder shall do proper sequencing of the various activities by suitably staggering the activities within various pockets in the plot so as to achieve early completion.

14. Project review meetings:

The Bidder, immediately on award of work shall submit details of his key personnel to be engaged for the work at site. In addition, he shall furnish the Employer detailed organization involved with the work.

Weekly Review Meetings: Shall be attended by Bidder / their representatives who can take independent decisions along with Engineer-in-charge and Bank's representatives.

15 Hardware and sanitary wares:

15.1 Engineer-in-Charge will take a decision regarding make of materials, model numbers of equivalent Door/window hardware/ sanitary ware at the time of execution, in case the stipulated make or model mentioned, is not available. However, in case, the equivalent make or model so approved, is cheaper than the make or model already mentioned in Preferred makes list, the price adjustment will be made based on the difference in market rate.

16. Inspection & Audit of works:

16.1 In addition to the provisions of relevant clauses of the contract, the work shall also be open to inspection by the Bank internal inspection and other Government authorities. The Bidder shall at times during the usual working hours and at all times at which reasonable notices of the intention of the Engineer-in-charge/ Employer or other authorized officers as stated above to visit the works shall have been given to the Bidder, either himself be present to receive the orders and instructions or have a responsible representative duly accredited in writing, to be present for that purpose.

16.2 Any instructions given by the above authorities shall be followed by the Bidder. Further any recoveries ordered by the above authorities shall be made from the amount payable to the Bidder or such amounts shall be paid by the Bidder to the Bank.

17. Submission of Insurance policies:

No work shall be commenced by the Bidder unless he obtains the Insurance Policies as mentioned under Clauses of contract. Also, no payment shall be made to the Bidder / no permission for continuation of works on expiry of insurance policies unless renewed by the Bidder. Nothing extra shall be payable on this account. No claim of hindrance (or any other claim) shall be entertained from the Bidder on these accounts.

18. Chasing work:

The work should be planned in a systematic manner so that chase cuttings in the walls, ceilings and floors is minimized. Wherever absolutely essential, the chase shall be cut using chase cutting machines. Chases will not be allowed to be cut using hammer / chisel. The electrical boxes should be fixed in walls simultaneously while raising the brick work. The Bidder shall ensure proper co-ordination of various disciplines viz. building works, sanitary & water supply &



electrical installations etc.

19. Warranty or Guarantee period for specialized works:

The warranty or Guarantee period for the works of water proofing and anti-termite shall be Ten (10) years from the date of completion of the works. The Bidder shall make good / rectify the defects occurring during the above period. Security deposit equivalent to 10% of the value of the item shall be retained by the Bank for a period of warranty/guarantee. The warranty/ guarantee shall be provided by the principal company for both material & application.

20. External Laboratory: Wherever tests are stipulated for the Materials, concrete etc the same shall be tested at any government, semi government or NABL approved private laboratories.

21. Licensed agencies: The Bidder shall engage licensed plumbers, electricians of required class as per the statutory rules for the works related to plumbing, sanitary, electrical works. Prior approval of the Employer shall be obtained by producing the copy of the Licenses before commencing these works.

22. Maintenance of Registers

The Bidder will be required to maintain the following registers at site of work and should produce the same for inspection of the Bank/ Engineer in charge wherever desired by them. Types of Register to be maintained are:

- | | | |
|------------------------|---|--------------------------------------|
| i) Register No. - III | : | Materials at Site Account |
| ii) Register No. - IV | : | Secured advance on materials at site |
| iii) Register No. - XI | : | Hindrance to work |
| iv) Register No.- XII | : | Running Account Bill |
| v) Register No.- XIII | : | Labour attendance |
| vi) Register No.- XIV | : | Labour Payment |



TECHNICAL SPECIFICATIONS FOR MODULAR FURNISHING WORKS

1. Specifications

1.1 Except for the items, for which Particular Specifications are given or where it is specifically mentioned otherwise in the description of the items in the schedule of quantities, the work shall generally be carried out in accordance with the "CPWD Specifications" additional / Particular Specifications, Architectural / structural drawings and as per instructions of Engineer-in-Charge.

1.2 All Technical Specifications in respect of all material to be used, method of execution, workmanship and quality for each item of the work shall be as per CPWD specifications and latest Indian Standard unless otherwise specified.

1.3 Any reference made to any Indian Standard Specifications, shall imply to the latest version of that standard, including such revisions / amendments as issued by the Bureau of Indian Standards up to last date of receipt of tenders.

1.4 The Contractor shall keep at his own cost all such publications including relevant Indian Standard Codes applicable to the work at site.

2. Materials :

Timber: Shall be of best quality as specified in the schedule of quantities perfectly dry, well seasoned and free from sap wood, sound straight, free from loose knots, cracks shakes and any appearance of rot and any other defect and conforming to IS: 12896 - 1990 and shall be approved by the engineer, No wood work shall be placed in position covered in the wall unless it is approved by the engineer.

Granite: Polished granite slab and tiles shall be of the kind specified in the schedule of quantities conforming to samples approved by the engineer for colour & texture. The slab shall be machine cut to required dimensions and shall conform to IS Standards.

Paints: Plastic emulsion painting will be of approved brand of paint and colour conforming to IS: 5411-1991 & will be applied over a coat of primer (including preparation of wall surface).

- Synthetic enamel paint will be of approved brand and colour confirming to IS 4511-1993 applied over one coat of primer.
- Oil bound distemper will be of approved brand and colour confirming to IS applied over one coat of primer.
- Acrylic wasable distemper will be of approved brand and colour confirming to IS applied over one coat of primer.

Aluminum - the material shall conform to IS 1285.

Structural steel - the materials shall conform to IS 808

Anti-termite treatment - the materials shall conform to IS 6313 part II

3. Makes of Materials: The makes of materials shall be as per the details furnished in the list of preferred makes.

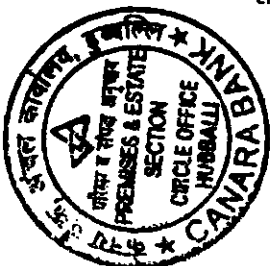

SAFETY CODE

i. > Suitable scaffolds should be provided for workmen for all works that cannot safely be done from the ground, or from solid construction except such short period work as can be done safely from ladders. When a ladder is used an extra mazdoor shall be engaged for holding the ladder and if the ladder is used for carrying materials as well, suitable footholds and handholds shall be provided on the ladder and the ladder shall be given an inclination not steeper than ¼ to 1 (¼ horizontal and 1vertical).

ii. > Scaffolding or staging more than 3.6 m (12 feet) above the ground or floor, swung or suspended from an overhead support or erected with stationary support shall have guard rail properly attached bolted, braced and otherwise secured at least 90 cm (3 feet) high above the floor or platform of such scaffolding or staging and extending along the entire length of the outside and ends thereof with only such opening as may be necessary for the delivery of materials. Such scaffolding or staging shall be so fastened as to prevent it from swaying from the building or structure.

iii. > Working platform, gangways, and stairways should be so constructed that they should not sag unduly or unequally, and if the height of the platform or the gangway or the stairway is more than 3.6m (12 feet) above ground level or floor level, they should be closely boarded, should have adequate width and should be suitably fastened as described in (ii)above.

iv. > Every opening in the floor of a building or in a working platform be provided with suitable means to prevent the fall of persons or materials by providing suitable fencing or railing whose minimum height shall be 90 cm (3feet).

v. > Safe means of access shall be provided to all working platforms and other working places. Every ladder shall be securely fixed. No portable single ladder shall be over 9 m. (30 feet) in length while the width between side rails in rung ladder shall in no case be less than 29 cm (11 ½ ") for ladder upto and including 3 m (10 feet)in length. For longer ladders this width should be increased at least ¼" for each additional 30 cm (1 foot) of length. Uniform step spacing shall not exceed 30 cm (12"). Adequate precautions shall be taken to prevent danger from electrical equipment. No materials on any of the sites of work shall be so stacked or placed as to cause danger or inconvenience to any person or the public. The contractor shall provide all necessary fencing and lights to protect the public from accident, and shall be bound to bear the expenses of defence of every suit, action or other proceedings at law that may be brought by any persons for injury sustained owing to neglect of the above precautions and to pay any damages and cost which may be awarded in any such suit, action or proceedings to any such person or which may, with the consent of the contractor, be paid to compromise any claim by any suchperson.

vi. > Excavation and Trenching :: All trenches, 1.2 m (four feet) or more in depth, shall at all times be supplied with at least one ladder for each 30 m. (100 feet) in length or fraction thereof. Ladder shall be extended from bottom of the trench to at least 90 cm (3 feet) above the surface of the ground. The side of the trenches which are 1.5 m (5 feet) or more in depth shall be stepped back to give suitable slope or securely held by timber bracing, so as to avoid the danger of

sides to collapse. The excavated material shall not be placed within 1.5m (5 feet) of the edges of the trench or half of the depth of the trench which ever is more. Cutting shall be done from top to bottom. Under no circumstances undermining or undercutting shall be done.

vii. > Demolition:: Before any demolition work is commenced and also during the process of the work:-

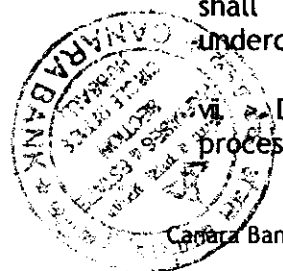

- a) All roads and open areas adjacent to the work site shall either be closed or suitably protected.
- b) No electric cable or apparatus which is liable to be a source of danger over a cable or apparatus used by the operator shall remain electrically charged.
- c) All practical steps shall be taken to prevent danger to persons employed from risk of fire or explosion or flooding. No floor, roof or other part of the building shall be so overloaded with debris or materials as to render it unsafe.

vii. > All necessary personal safety equipment as considered adequate by the Engineer-in-Charge should be kept available for the use of the person employed on the site and maintained in a condition suitable for immediate use, and the contractor should take adequate steps to ensure proper use of equipment by those concerned:-

- a. Workers employed on mixing asphaltic materials, cement and lime mortars shall be provided with protective footwear and protective goggles.
- b. Those engaged in white washing and mixing or stacking of cement bags or any material which is injurious to the eyes shall be provided with protective goggles.
- c. Those engaged in welding works shall be provided with welder's protective eyeshields.
- d. Stone breakers shall be provided with protective goggles and protective clothing and seated at sufficiently safe intervals.
- e. When workers are employed in sewers and manholes, which are in use, the contractors shall ensure that the manhole covers are opened and ventilated at least for an hour before the workers are allowed to get into the manholes, and the manholes so opened shall be cordoned off with suitable railing and provided with warning signals or boards to prevent accident to the public.
- f. When workers are employed in sewers and manholes, which are in active use, the contractor shall ensure that the following safety measures are adhered to:-

- i) Entry for workers into the line shall not be allowed except under supervision of the Architect or any other higher officer.
- ii) At least 5 to 6 manholes upstream and downstream should be kept open for at least 2 to 3 hours before any man is allowed to enter into the Manholes for working inside.
- iii) Before entry, presence of toxic gases should be tested by inserting wet lead acetate paper, which changes colour in the presence of such gases and gives indication of their presence.
- iv) Presence of oxygen should be verified by lowering a detector lamp into the manhole. In case, no oxygen is found inside the sewer line, workers should be sent only with Oxygen kit.
- v) Safety belt with rope should be provided to the workers. While working inside the manholes such rope should be handled by two men standing outside to enable him to be pulled out during emergency.
- vi) No smoking or open flames be allowed near the blocked manholes being cleaned.
- vii) The Malba obtained on account of cleaning of blocked manholes and sewer lines should be immediately removed to avoid accidents on account of slippery nature of the malba.
- viii) Workers should not be allowed to work inside the manhole continuously. He should be given rest intermittently. The Engineer-in-Charge may decide the time up to which a worker may be allowed to work continuously inside the manhole.

Gas masks with oxygen cylinder should be kept at site for use in emergency.

Air blowers should be used for flow of fresh air through the manholes.



Whenever called for, Portable air blowers are recommended for ventilating the manholes. The Motors for these shall be vapour proof and of totally enclosed type. Non sparking gas engines also could be used but they should be placed at least 2 meters away from the opening and on the lowered side protected from wind so that they will not be source of friction on any inflammable gas that might be present.

- x) The workers engaged for cleaning the manholes/sewers should be properly trained before allowing to work in themanhole.
 - xi) The workers shall be provided with Gumboots or non-sparkling shoes, bump helmets and gloves, non-sparkling tools, safety lights and gas masks and portable air blowers (when necessary). They must be supplied with barrier cream for anointing the limbs before working inside the sewerlines.
 - xii) Workmen descending a manhole shall try each ladder step or rung carefully before putting his full weight on it to guard against insecure fastening due to corrosion of the rung fixed to manholewall.
 - xiii) If a man has received a physical injury he should be brought out of the sewer immediately and adequate medical aid should be provided tohim.
 - xiv) The extent to which these precautions are to be taken depend on individual situation but the decision of the Engineer in charge regarding the steps in this regard to be taken in an individual case will be final".
- g. The contractor shall not employ men below the age of 18 years and women on the work of painting with products containing lead in any form. Wherever men above the age of 18 are employed on the work of lead painting, the following precautions should be taken::
- i) NO paint containing lead or lead products shall be used except in the form of paste or readymadepaint.
 - ii) Suitable face masks should be supplied for use by the workers when paint is applied in the form of spray or a surface having lead paint dry rubbed and scrapped.
 - iii) Overalls shall be supplied by the contractors to the workmen and adequate facilities shall be provided to enable the working painters to wash during the cessation ofwork.

Whenever men above the age of 18 are employed on the work of lead painting, the following principles must be observed for such use::

I. a. White lead, sulphaste of lead, or products containing these pigments shall not be used in painting operation except in the form of paste or of paint ready for use.

b. Measures shall be taken in order to prevent danger arising from the application of paint in the form of spray.

c. Measures shall be taken, whenever practicable, to prevent danger arising from dust caused by dry rubbing down and scraping.

II .a. Adequate facilities shall be provided to enable working painters to wash during and on cessation ofwork.

b. Overall shall be worn by all the working painters during the whole of the working period.

c. Suitable arrangements shall be made to prevent clothing put off during working hours being soiled by painting materials.

III .a. Cases of lead poisoning and of suspected lead poisoning shall be notified and subsequently verified by a medical man appointed by the competent authorities of

theEmployee.

b. The Employer may require, when necessary a medical examination of workers.

c. Instructions with regard to the special hygienic precautions to be taken if the painting work shall be distributed to working painters.

ix > When the work is done near any place where there is risk of drowning, all necessary equipment's should be provided and kept ready for use and all necessary steps taken for prompt rescue of the person in danger and adequate provision should be made for prompt first aid treatment of all injuries likely to be sustained during the course of the work.

x > Use of hoisting machines and tackle including their attachments, anchorage and supports shall conform to the following standards or conditions::

1) a. These shall be of good mechanical construction, sound material and adequate strength and free from patent defects and shall be kept in good repair and in good working order.

b) Every rope used in hoisting or lowering materials or as a means of suspension shall be of durable quality and adequate strength, and free from patent defects.

2). Every crane driver or hoisting appliance operator shall be properly qualified and no person under the age of 21 years should be in charge of any hoisting machine including any scaffolding winch or give signals to operator.

3). In case of every hoisting machine and of every chain ring hook, shackle swivel and pulley block used in hoisting or a means of suspension the safe working load shall be ascertained by adequate means. Every hoisting machine and all gear referred to above shall be plainly marked with the safe working load. In case of a hoisting machine having a variable safe working load, each safe working load and the conditions under which it is applicable shall be clearly indicated. No part of any machine or any gear referred to above in this paragraph shall be loaded beyond the safe working load except for the purpose of testing.

4). In case of Employer's machines, the safe working load shall be notified by the Electrical Engineer-in-Charge. As regards contractors' machines the contractors shall notify the safe working load of the machine to the Engineer-in-Charge whenever he brings any machinery to site of work and get it verified by the Electrical Engineer concerned.

xi > Motors, gearing, transmission, electric wiring and other dangerous parts of hoisting appliances should be provided with efficient safeguards. Hoisting appliances should be provided with such means as will reduce to the minimum the risk of accidental descent of the load. Adequate precautions should be taken to reduce to the minimum the risk of any part of a suspended load becoming accidentally displaced. When workers employed on electrical installations which are already energised, insulating mats, wearing apparel, such as gloves, sleeves and boots as may be necessary should be provided. The workers should not wear any rings, watches and carry keys or other materials which are the good conductors of electricity.

xii > All scaffolds, ladders and other safety devices mentioned or described herein shall be maintained in safe conditions and no scaffold, ladder or equipment shall be altered or removed while it is in use. Adequate washing facilities should be provided for near places or work.

> These safety provisions should be brought to the notice of all concerned by

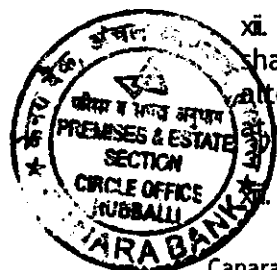

display on a notice board at a prominent place at work spot. The person responsible for compliance of the safety code shall be named therein by the contractor.

xiv. > To ensure effective enforcement of the rules and regulations relating to safety precautions the arrangements made by the contractor shall be open to inspection by the Labour Officer of the Government, Engineer-in-Charge of the Employer or their representatives.

xv. > Notwithstanding the above clauses from (i) to (xiv) there is nothing in these to exempt the contractor from the operations of any other Act or Rule in force in the Republic of India.



MODEL RULES FOR PROTECTION OF HEALTH AND SANITARY ARRANGEMENTS FOR WORKERS EMPLOYED BY CONTRACTORS

1>. Application::

These rules shall apply to all building and construction works in which twenty or more workers are ordinarily employed or are proposed to be employed on any day during the period during which the contract work is in progress.

2>. Definition::

Work place means a place where twenty or more workers are ordinarily employed or are proposed to be employed in connection with construction work on any day during the period during which the contract work is in progress.

3>. First Aid facilities::

(1) At every work place there shall be provided and maintained, so as to be easily accessible during working hours, first-aid boxes at the rate of not less than one box for 150 contract labour or part there of ordinarily employed.

(2) The first-aid box shall be distinctly marked with a red cross on white ground and shall contain the following equipment, namely:-

a. > For work places in which the number of contract labour employed does not exceed 50-

Each first-aid box shall contain the following equipments:-

- i. 6 small sterilised dressings.
- ii. 3 medium size sterilised dressings.
- iii. 3 large size sterilised burn dressings.
- iv. 1 (30 ml.) bottle containing a two percent alcoholic solution of iodine.
- v. 1 (30 ml.) bottle containing sal volatile having the dose and mode of administration indicated on the label.
- vi. 1 snake-bit lancet.
- vii. 1 (30 gms) bottle of potassium permanganate crystals.
- viii. 1 pair scissors.
- ix. 1 copy of the first aid leaflet issued by the Director General, Factory Advice Service and Labour Institutes, Government of India.
- x. 1 bottle containing 100 tablets (each of 5 grams) of aspirin.
- xi. Ointment for burns.
- xii. A bottle of suitable surgical antiseptic solution.

b. > For work places in which the number of contract labour exceed 50 -

Each first-aid box shall contain the following equipments:-

- i. 12 small sterilized dressings.
- ii. 6 medium size sterilized dressings.
- iii. 6 large size sterilized dressings.
- iv. 6 large size sterilised burn dressings.

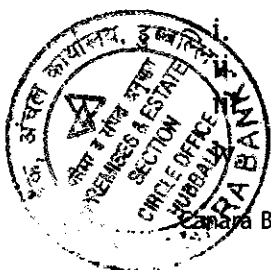

- v. 6 (15 gms) packets sterilised cottonwool.
- vi. 1 (60 ml.) bottle containing a two percent alcoholic solution iodine.
- vii. 1 (60 ml.) bottle containing sulvolatile having the dose and mode of administration indicated on the label.
- viii. 1 roll of adhesive plaster.
- ix. 1 snake bite lancet.
- x. 1 (30 gms.) bottle of pottasium permanganate crystals.
- xi. 1 pair scissors.
- xii. 1 copy of the first-aid leaf-let issued by the Director General, Factory Advice Service and Labour Institutes, Government of India.
- xiii. A bottle containing 100 tablets (each of 5 grams) of aspirin.
- xiv. Ointment for burns.
- xv. A bottle of suitable surgical antiseptic solution.

(3) Adequate arrangements shall be made for immediate recoument of the equipment when necessary.

(4) Nothing except the prescribed contents shall be kept in the First-aid box.

(5) The first Aid box shall be kept in charge of a responsible person who shall always be readily available during the working hours of workplace.

(6) A person in charge of the First Aid box shall be a person trained in First-Aid treatment, in work places where the number of contract labour employed is 150 or more.

(7) In work places where the number of contract labour employed is 500 or more and hospital facilities are not available within easy distance of the works. First/Aid posts shall be established and run by a trained compounder. The Compounder shall be on duty and shall be available at all hours when the workers are at work.

(8) Where work places are situated in places which are not towns or cities, a suitable motor transport shall be kept readily available to convey injured person or person suddenly taken ill to the nearest hospital.

4>. Drinking water::

(a) In every work place there shall be provided and maintained at suitable places, easily accessible to labour, a sufficient supply of cold water fit for drinking.

(b) Where drinking water is obtained from an intermittent public water supply, each work place shall be provided with storage where such drinking water shall be stored.

(c) Every water supply of storage shall be at a distance of not less than 50 feet from any latrine, drain or other source of pollution. Where water has to be drawn from an existing well which is within such proximity of latrine, drain or any other source of pollution, the well shall be properly chlorinated before water is drawn from it for drinking. All such wells shall be entirely closed in and be provided with a trap-door which shall be dust and water-proof.

(d) A reliable pump shall be fitted to each covered well, the trap-door shall be kept locked and opened only for cleaning or inspection which shall be done at least once a month.

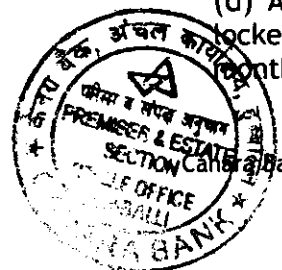

5>. Washing facilities::

- (i) In every work place adequate and suitable facilities for washing shall be provided and maintained for the use of contract labour employed therein.
- (ii) Separate and adequate screening facilities shall be provided for the use of male and female workers.
- (iii) Such facilities shall be conveniently accessible and shall be kept in clean and hygienic condition.

6>. Latrines and Urinals::

- (i) Latrines shall be provided in every work place on the following scale, namely:-
 - (a) Where females are employed there shall be at least one latrine for every 25 females.
 - (b) Where males are employed, there shall be at least one latrine for every 25 males.

Provided that where the number of males or female exceeds 100, it shall be sufficient if there is one latrine for 25 males or females, as the case may be, upto the first 100 and one for every 50 thereafter.

(ii) Every latrine shall be under cover and so partitioned off as to secure privacy, and shall have proper door and fastenings.

(iii) Construction of latrines:: The inside walls shall be constructed of masonry or some suitable heat-resisting non-absorbent materials and shall be cement washed inside and outside at least once a year. Latrines shall not be of a standard lower than bore-hole system.

(iv) a. Where workers of both sexes are employed, there shall be displayed outside each block of latrine and urinal, a notice in the language understood by the majority of the workers "For Men only" or "For Women Only" as the case may be.

a. The notice shall also bear the figure of a man or of a woman as the case may be.

(v) There shall be at least one urinal for male workers upto 50 and one for female workers upto fifty employed at a time. Provided that where the number of male or female workmen, as the case may be, exceeds 500, it shall be sufficient if there is one urinal for every 50 males or females upto the first 500 and one for every 100 or part thereof, thereafter.

(vi) a. The latrines and urinals shall be adequately lighted and shall be maintained in a clean and sanitary condition at all times.

b. Latrines and urinals other than those connected with a flush sewerage system shall comply with the requirements of the Public Health Authorities.

(i) Water shall be provided by means of a tap or otherwise so as to be conveniently accessible in or near the latrines and urinals.

(viii) Disposal of excreta:: Unless otherwise arranged for by the local sanitary authority, arrangements for proper disposal of excreta by incineration at the work

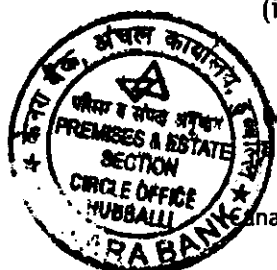

place shall be made by means of a suitable incinerator. Alternately excreta may be disposed of by putting a layer of night soil at the bottom of a pucca tank prepared for the purpose and covering it with a 15 cm layer of waste or refuse and then covering it with a layer of earth for a fortnight (when it will turn into manure).

(ix) The contractor shall, at his own expense, carry out all instructions issued to him by the Engineer-in-Charge to effect proper disposal of soil and other conservancy work in respect of the contractors' workmen or employees on the site. The contractor shall be responsible for payment of any charges which may be levied by Municipal or Cantonment Authority for execution of such work on his behalf.

7>. Provision of shelter during rest::

At every place there shall be provided, free of cost, four suitable sheds, two for meals and the other two for rest separately for the use of men and women labour. The height of each shelter shall not be less than 3 meters from the floor level to the lowest part of the roof. These shall be kept clean and the space provided shall be on the basis of 0.6 sq.mt. perhead.

Provided that the Engineer-in-Charge may permit, subject to his satisfaction, a portion of the building under construction or other alternative accommodation to be used for the purpose.

8>. Creches::

(a) At every work place, at which 20 or more women worker are ordinarily employed, there shall be provided two rooms of reasonable dimensions for the use of their children under the age of six years one room shall be used as a play room for the children and the other as their bed-room. The rooms shall be constructed with the specification as similar to these given in para 2 (a) of clause 19H.

(b) The rooms shall be provided with suitable and sufficient openings for light and ventilation. There shall be adequate provision of sweepers to keep the places clean.

(c) The contractor shall supply adequate number of toys and games in the play room and sufficient number of cots and bedding in the bedroom.

(d) The contractor shall provide one dais to look after the children in the creches when the number of women workers does not exceed 50 and two dais when the number of women workers exceed 50.

(e) The use of the rooms earmarked as creches shall be restricted to children, their attendants and mothers of the children.

9>. Anti-Malarial precautions::

The contractor shall at his own expense, conform to all anti-malarial instructions including the filling up of any borrow pits which may have been dug by him.

◆ ◆ ◆ ◆ ◆ ◆ ◆ ◆



LIST OF APPROVED MAKE;

All Materials Shall confirm to relevant standards and ISI marked

Sl.No	Items	Preferred Makes
1.	Acrylic emulsion paints / synthetic enamel paint	Asian Paints /Dulux paints / Berger / Nerolac
2.	POP/Wall putty	Birla white / JK / Asian /Dulux
3.	Plywood	Samrat, Century, Archid, Greenply, Kitply,
4.	Glazing / glass	Indo - asia / Modi float / Saint Gobain/AIS Float /Asahi India glassworks Ltd
5.	Laminates	Century Mica, Formica, Greenlam, Merino, Sunmica- AICA, Archidlam,
6.	Locks	Godrej / Link/Ebco
7.	Brass hardware	Saifee, tube & hardware, Gopi,Becker
8.	Veneers	Green deco veneers, Archid, Timex.
9.	Polish	Light house, Sheenlac
10.	Sliding Channels	Ebco/Godrej/Hittech/Ozone
11.	Teak wood	Second class quality Indian Teak
12.	Door Closer	Dorma, Everite, Hardwyn
13.	Aluminum sections	Extruded sections of Jindal, Hindalco, Indal
14.	Adhesive	FEVICOL, vamicol, araldite
15.	Beechwood	As approved by the consultant
16.	Block board	Samrat, Century, Archid, Greenply
17.	Plaster boards	LAGYP or as approved

Note:

Regarding selecting the make against each item among the preferred makes as specified above, decision of Employer shall be final. If the makes as mentioned above are not available at the time of execution, the contractor shall get the make approved from the engineer-in-charge and employer before using the same in the work.

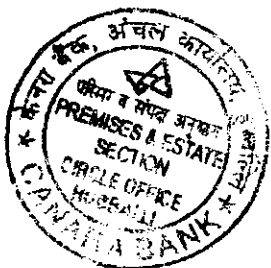

Canara Bank Circle Office Hubballi

<Page no. 81>

Signature of Tenderer with Seal

T E N D E R F O R M

To,
The Deputy General Manager
Canara Bank
Circle Office, 52A, Shanbhag
Building, Unkal Cross,
Sai Nagar Road, Hubballi

Name of work: Interior furnishing works of Circle office, at 2nd Floor V2 building,
Property No.98/4, Airport Road, Hubballi-580030

I/We have read and examined the notice inviting tender. Schedules A,B,C,D,E & F, specifications applicable, Drawings and Designs, General Rules and Directions, Conditions of Contract, clauses of contract, Special conditions, Schedule of Rate and all other documents and Rules referred to in the conditions of contract and all other contents in the tender document for the work.

I/We hereby tender for the execution of the work specified for the Canara Bank within the time specified in Schedule 'F' at the rates specified in the attached Schedule 'A' viz., schedule of quantities and in accordance in all respects with the specifications, designs drawings and instructions in writing referred to in Rule-1 of General Rules and Directions and in Clause 11 of the conditions of contract and with such materials as are provided for, by, and in all respects in accordance with, such conditions so far as applicable.

I/We agree to keep the tender open for hundred and twenty days from the due date of submission thereof and not to make any modifications in its terms and conditions.

A sum of Rs. _____ is hereby forwarded in Demand Draft / BG of _____ Bank as Earnest Money Deposit. If I/We, fail to commence the work specified I/We agree that the Bank shall without prejudice to any other right or remedy, be at liberty to forfeit the said earnest money absolutely otherwise the said earnest money shall be retained by it towards security deposit to execute all the works referred to in the tender documents upon the terms and conditions contained or referred to therein and to carry out such deviations as may be ordered, upto maximum of the percentage mentioned in Schedule 'F' and those in excess of that limit at the rates to be determined in accordance with the provision contained in Clauses 12.2 and 12.3 of the tenderform.

I/We hereby declare that I/We treat the tender documents, drawings and other records connected with the work as secret/confidential documents and shall not communicate information/derived therefrom to any persons other than a person to whom I/We am / are authorised to communicate the same or use the information in any manner prejudiced to the safety of the state.

I/We fully understand that you are not bound to accept the lowest or any tender you may receive.

Shri. _____, Partner/Proprietor/
_____ is the person authorized to negotiate commercial and technical terms and conditions and sign on behalf of the firm any Agreement, Bills and receipts for this work.

I/We agree that should I/We fail to deposit the full amount of initial security deposit and/or fail to commence the work specified in the above memorandum, an amount equal to the amount of the earnest money mentioned in the form of invitation of tender shall be absolutely forfeited to the Canara Bank and the same, may at the option of the Canara Bank be recovered without prejudice to any other right or remedy available in law, out of the deposit so far as the same may extend in terms of the said bond and in the event of deficiency out of other money due to me/us under this contract or otherwise.

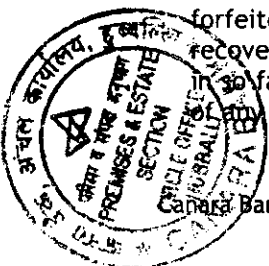

I/We agree that until a formal agreement on stamp paper is prepared and signed, this tender with your written acceptance thereof shall constitute a binding contract between us.

Dated the: ___dayof__2020 Witness:

Nam

e:

Signature of Contractor Full Postal
Address
Pin Code No. &
Telephone No.

Address

:

Occupation:

◆ ◆ ◆ ◆ ◆ ◆ ◆ ◆



ANNEXURE-1:

BIO DATA OF THE TENDERER

(a) Name of the Tenderer :

Address :

Telephone No. :

Office :

Residence :

Mobile :

Fax :

E-Mail :

(b) Address of office :

a) Status of the Firm(Whether company/
Partnership / proprietary) :

b) Name of the Proprietor/ Partners/ Directors
(With professional qualifications, if any):

I)

II)

III)

c) Year of establishment :

2 Whether registered with Registrar of
Companies/ firm. If so, No.&Date :

2. Registration with Tax Authorities :

a) Income-tax No. PAN;
(Furnish copies of Income-tax returns)

b) GST Registration Number :
(Furnish the latest copies of the returns filed)

c) Electrical license number & name
of: associate if available

d) Value Added Tax (VAT) registration details:

3 Names of the Bankers with address :

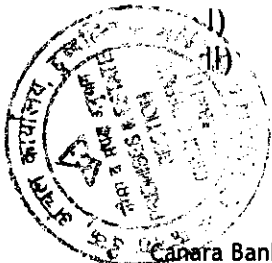

Turnover of the Company/firm (Please attach copy of documents in support of the details).

Sl.No	Year	Turnover
1	2017-18	
2	2018-19	
3	2019-20	

3. Registration / Empanelment with Government / Public Sector / Banks / Corporate if any (Copy of valid registration / empanelment copy should be enclosed).

NAME OF THE ORGANISATION	NATURE OF WORKS	VALUE OF WORKS	DATE OF REGISTRATION

4 4. What are your fields of activities? Mention the fields on
5 preference Basis

6 1)

2)

3)

5. Details of the works executed during the last 7 years prior to 30.09.2020 to meet Sl. No- 4 of Eligibility Criteria.

Sl. No	Name of Work	Work executed for (name of the organization with address, concerned office and telephone number)	Nature of work (in brief)	Location of the work	Actual Value of the works	Date of commencement & Completion.

Key personnel permanently employed in your organization:

Sl. No	Name	Qualifications	Experience	Particulars of work done	Employed in your firmsince	Any other

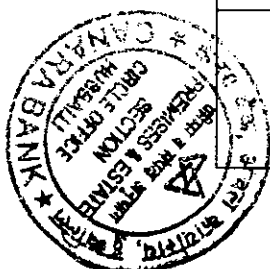

6. Furnish the names of three responsible clients / persons to whom the major works carried out by the applicant with address and telephone number who will be in a position to certify about the quality as well as past performance of your organization.

NAME OF THE OFFICIAL	ORGANISATION & ADDRESS	CONTACT NUMBERS

7. Furnish the details of AWARDS, CITATIONS, etc., received in recognition of your services in projects designed / associated

YEAR	Name of the Award with details	Name of the organization from whom award was received	Name of the project for which such award was received

DECLARATION:

1. All the information furnished by me / us here above is correct to the best of my knowledge and belief.
2. I / we have no objection if enquiries are made about the work listed by me / us in the accompanying sheets / annexure.
3. I / We agree that the decision of Bank in selection will be final and binding to me / us.

Place :

SIGNATURE

Date :

NAME & DESIGNATION
SEAL OF ORGANISATION

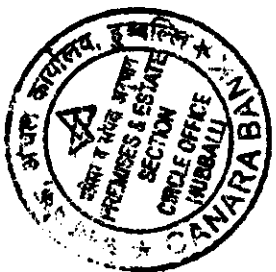

ANNEXURE-2:

ACCEPTANCE

The above tender (as modified by us or negotiations as provided in the letters mentioned hereunder) is accepted by me for and on behalf of the Canara Bank for a sum of Rs. _____ (Rupees _____)

The letters referred to below shall also form part of this contract agreement: a)

b)

c)

For & on behalf of the Canara

Bank Signature: _____

Designation: _____

Dated this _____ day of 2020.

◆ ◆ ◆ ◆ ◆ ◆ ◆ ◆ ◆



ANNEXURE-3:

FORM OF AGREEMENT

This agreement made on the _____ day of the month of _____ in the year 2020 BETWEEN, Canara Bank a body corporate constituted under the Banking Companies (Acquisition and Transfer of Undertakings) Act, 1970, having its Circle Office, at 52A, Shanbhag Building, Unkal Cross, Sai Nagar Road, Hubballi represented by Circle Office, _____ its _____ duly constituted attorney (hereinafter referred to as Bank) of the ONE PART; and Shri/M/s _____ S/D/o _____ resident of the sole proprietor of M/s _____ having office at _____

_____/the partnership firm represented by its Managing / duly authorised partner, having an administrative / principal office at _____ / a company / body corporate being its registered office at _____ duly represented at _____

duly represented by its constituted and authorised Managing Director, Shri _____ and (hereinafter called the Contractor) of the other part

WHEREAS THE Bank is desirous that certain works should be constructed viz., _____

and has accepted the tender dt. _____

furnished by the contractor for the constructions, completion and performance of such works.

NOW THIS AGREEMENT WITNESSETH as follows:

1. In this agreement words and expression shall have the same meanings as are respectively assigned to them in the conditions of contract hereinafter referred to.

2. The following documents not inconsistent with these presents shall be deemed to form and be read and construed as part of this agreement viz.,

- a) Notice inviting Tender
- b) The Tenderform
- c) General Rules and Directions totenderers.
- d) Conditions of contract and clauses of contract along with Annexures thereto and Schedules A to F.
- e) Schedule of quantities (SOQ) includes Prices and tendered amount.
- f) Tender drawings.
- g) Technical Specifications for the work.
- h) Safety code and Model rules for the protection of health, sanitary arrangements for worker employed.
- i) Letter of Acceptance.
- j) Letters from and to the Contractor, if any, leading to and prior to acceptance letter.

In consideration of the payments to be made by the Bank to the Contractor the Contractor hereby covenants and agrees with the Bank to construct, complete and perform the works in conformity in all respects and subject to all terms and conditions/rules as mentioned in the aforesaid documents which shall be binding on the Contractor from part of this agreement.

In witness whereof the parties hereto have hereunto set their respective hands and seals the day and year first above written.

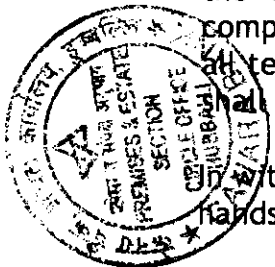

Signed, sealed and delivered by the said contractor, _____
to bank _____ in the presence of:

Signature of the Contractor (with seal)

Signature of Bank Official (with seal)

◆ ◆ ◆ ◆ ◆ ◆ ◆ ◆



ANNEXURE-4:

**DETAILED LIST OF PLANTS AND EQUIPMENT AVAILABLE WITH
THE CONTRACTOR FOR USE ON THIS WORK.**

Sl. No	Name and Description of the Equipments	Make & Year
1.		
2.		
3.		
4.		
5.		
6.		
7.		
8.		

Signature of the Contractor (with seal)

◆ ◆ ◆ ◆ ◆ ◆ ◆ ◆

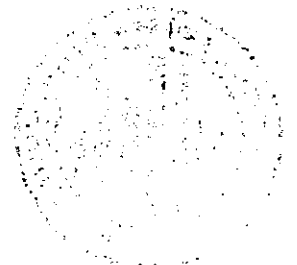

ANNEXURE-5:

LIST OF RELATIVES EMPLOYED IN CANARA BANK AND WITH THE ARCHITECT FOR THIS WORK.

Sl. No	Name	Designation	Branch/ Office of Bank / Architect	Relationship with Contractor
1.				
2.				
3.				
4.				
5.				

Signature of the Contractor(with seal)

◆ ◆ ◆ ◆ ◆ ◆ ◆ ◆



ANNEXURE-6:**FORMAT OF RECEIPT OF MATERIALS AT SITE**

Sr. No	Description	Opening balance	Receipt during month	Consumption during month	Closing balance	Total quantity received till date
1						
2						
3						
4						
5						
6						
7						
8						

Sl. No	Description of work	Date of Commencement	Due date of completion	Percentage progress achieved
1				
2				
3				
4				
5				
6				
7				

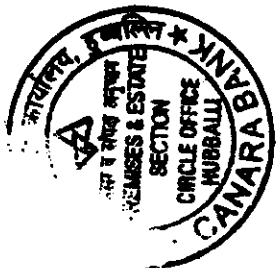

ANNEXURE-7:

FORMAT OF MEASUREMENT BOOK

MEASUREMENT BOOK PAGES NOS. 1 TO

Tender Item No.	Description	Measurement details			Quantity	Remarks
		L	B	D/H		

Site Engineer

Architect

Contractor Checking/Test checking Engineer

Date of checking/Testchecking

NOTE:

Checking and test checking pertains to items wherever initialed.

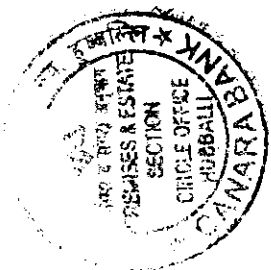

ANNEXURE-8:**FORMAT FOR RUNNING BILL**

I. Running

A/C

Bill

- i) Name of Contractor /Agency:
 ii) Name of work:
 iii) Sl. No. of this bill:
 iv) No. and date of previous bill:
 v) Reference to Agreement No:
 vi) Date of written order to commence:
 vii) Date of completion as per agreement:

Sl. No.	Item Description	Unit	Rate (Rs.)	As per tender Qty, Amount (Rs.)
1.	2.	3.	4.	5.

Up to previous R/A Bill	Upto date (Gross)	Present Bill	Remark
Qty. Amount (Rs.)	Qty. Amount (Rs.)	Qty. Amount (Rs.)	
6.	7.	8.	9.

Note:

- 1) If part rate is allowed for any item, it should be _____ indicated with reasons for allowing such a rate. Net value since
- 2) If ad hoc payment is made, it should be mentioned previous bill specifically.

II. ACCOUNT OF SECURED ADVANCE, IF ADMISSIBLE ON MATERIALS HELD AT SITE BY THE CONTRACTOR

No.	Item	Quantity	Unit	Amount	Remarks
1.	2.	3.	4.	5.	6

Total value of materials at site.

Secured Advance @ _____ % of above value B



CERTIFIED (i) that the materials mentioned above have actually been brought by the contractor to the site of the work and no advance on any quantity of any of this item is outstanding on their security (ii) that the materials are of imperishable nature and are all required by the contractor for use in the work in connection with the items for which rates of finished work have been agreed upon.

Dated signature of Site Engineer

Preparing the bill

Designation _____

Dated signature of Bank's Architects

(Name of the Architects)

Dated signature of Contractor

CERTIFICATE

The measurements on the basis of which the above entries for the Running Bill No. _____ were made have been taken jointly on _____ and are recorded at pages _____ to _____ of measurement book No. _____

The work recorded in the above mentioned measurements has been done at the site satisfactorily as per tender drawings, conditions and specifications.

Signature of Contractor or contractor's representative	Signature of Architect or Architect's representative
Date	Date
Seal	Seal

Test Check by Bank's authorized representative	
Signature of Bank Official	
Date	
Seal	

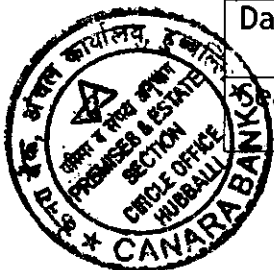

ANNEXURE-9:

FORMAT FOR RATE ANALYSIS OF ITEMS

I.	MATERIAL	
	1. Basic Cost of Material	Rs. _____
	2. Wastage -5%	- Rs. _____
II.	Labour: As per Standard Labour output and labour input required for the Particular item using quoted labour rates.	- Rs. _____
III.	Machinery/Tools Inputs of Machinery / Tools requirements as per the item and hire charges as per market.	- Rs. _____
	TOTAL (I) + (II)+(III)	Rs. _____
IV.	Tax Liability [As per contractual clauses will be added]	Rs. _____
V.	Add - ½ % for water charges	Rs. _____
	½ % for Electricity	Rs. _____
VI.	Any other Expenditure (please specify)	Rs. _____
	TOTAL	
	Contractor Profit & OH-15%	Rs. _____
	GRAND TOTAL	Rs. _____

TDS will be deducted as per standard norms and recovery shall be made for water and electricity as per tender conditions.



ANNEXURE-10:

FORMAT OF CERTIFICATE OF PAYMENT

Certificate No. Interim /	Dated	
	Project No.	Electrical work
	Particulars:	
Contractor:	Contract / Letter No.	Dated:
	Contractor's Bill No.	Dated:
<p>This is to certify that the amount given below (*) is due to your Contractors for the work done by them and/or against materials delivered at site and/or for advance towards contract on the above referred project.</p> <p>Advance against contractRs _____ Less: Advance adjusted to-dateRs. _____</p> <p>Balance AdvanceRs. _____ Advance against material delivered at site Rs. _____ Amount of work done to-dateRs. _____ TotalRs. _____ Less: Retention on work doneRs _____</p> <p>_____ Less : previously certified uptoRs _____ _____ PRE SENT CERTIFICATE (*) Rs. _____ RUPEES.....</p> <p>The cost of cement or any other material supplied by you or payments made by you directly, if any and not covered herein above, should be adjusted before making the payment of the certificate amount (*).</p> <p>Necessary Deduction U/S194C of the income Tax 1961 and sales tax may be made before paying the above certified amount.</p> <p>By a copy of this letter, we are intimating the Contractors to call on you for the necessary payments.</p> <p>Remarks if any: The details of Insurance policy are given in the next page.</p> <p>Signature of Architects</p>		
Enclosures : Bill		

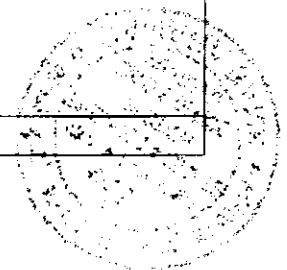
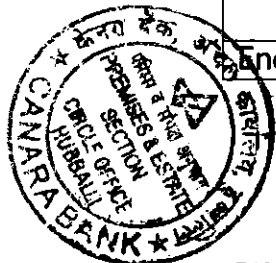

ANNEXURE-11:

FORMAT OF SITE ORDER BOOK

Name of the work _____

Date of Commencement _____

Sl. No	Remarks/ Instructions of the site Engineer/ Architect	Dated Initials of site Engineer/ Architect	Initials of the Contractor for having received the instructions	Action taken with date	Dated initials of the site Engineer	Remarks of the Architects PMC/C.C. Officials
1	2	3	4	5	6	7



ANNEXURE-12:**FORMAT FOR APPLICATION BY CONTRACTOR FOR EXTENSION OF TIME**

1	Name of the Contractor			
2	Name of the work as given in the Agreement			
3	Agreement WO			
4	Tender amount			
5	Date of commencement of work			
6	Period allowed for completion as per agreement			
7	Date of completion as per agreement			
8	Period for which extension of time has been given			
		<u>Date</u>	<u>Month</u>	<u>Year</u>
	a) 1 st extension vide Bank's Letter No.			
	b) 2 nd extension vide Bank's Letter No.			
	c) 3 rd extension vide Bank's Letter No.			
9	Reasons for which extensions have been previously given (copies of the previous applications should be attached)			
10	Period for which extension is applied for and the reasons thereof including hindrances, time for extra work assigned, if any etc.			



ANNEXURE-14:

Bank Guarantee Format for Earnest Money Deposit

To
The Deputy General Manager
Circle Office, Canara
Bank, 52A, Shanbhag
Building, Unkal Cross,
Sai Nagar Road,
Hubballi.

WHEREAS _____ (Name of Tenderer) (hereinafter called "the Tenderer" has submitted its tender dated _____ (Date) for the execution of (Name of Contract) _____ (hereinafter called "the Tender") in favour of CANARABANK, _____ hereinafter called the "Beneficiary";

KNOW ALL MEN by these presents that we, _____ (name of the issuing Bank), a body corporate constituted under the _____ having its Head Office at _____ amongst others a branch / office at _____ (hereinafter called "the Bank" are bound unto the Beneficiary for the sum of Rs _____ (Rupees only) for which payment well and truly to be made to the said Beneficiary, the Bank binds itself, its successors and assigns by these presents;

THE CONDITIONS of this obligation are:

- (a) If the Tenderer withdraws its Tender during the period of Tender validity specified in the Tender; or
- (b) If the Tenderer having been notified of the acceptance of his Tender by the Beneficiary during the period of Tender validity;
 - (i) fails or refuses to execute the Agreement, if required ; or
 - (ii) fails or refuses to furnish the performance security, in accordance with clause _____ of conditions of Contract.

We undertake to pay to the Beneficiary up to the above amount upon receipt of his first written demand without the Beneficiary having to substantiate his demand, provided that in his demand the Beneficiary will note that the amount claimed by him is due to him owing to the occurrence of one or both of the two conditions, specifying the occurred condition or conditions.

Notwithstanding anything contained herein

- i) Our liability under this Bank Guarantee shall not exceed Rs. _____ (Rupees _____ only)
- ii) This Bank Guarantee is valid upto _____ and
- iii) We are liable to pay the guaranteed amount or any part thereof under this Bank Guarantee only and only if you serve upon us a written claim or demand on or before _____ (mention period of guarantee as found under clause (ii) above plus claim period)

Dated _____ day of _____ 2020

SIGNATURE & SEAL OF THE BANK

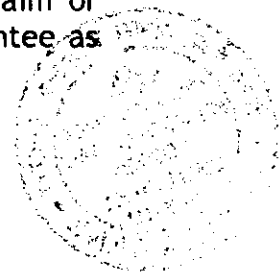

ANNEXURE-15:

BANK GUARANTEE FORMAT FOR SECURITY DEPOSIT

Guarantee No.....
Amount of Guarantee Rs.....
Guarantee cover from Dated:
To Dated:
Last Date for Lodgement of claim:

To:

In consideration of (hereinafter called "Beneficiary")
having agreed to exempt Ltd., having its Registered
Office situated at (hereinafter called the "the
obligator(s)") from the demand of security deposit of Rs
..... (Rup
ees

..... only) under the terms and conditions of an
agreement dated (hereinafter called the "said Agreement") for the
due fulfillment by the said obligator of the terms and conditions contained in the
said agreement, on production of the Bank Guarantee for Rs
..... (Rup
ees

..... only), at the request of the obligator _____ Bank, a
body corporate constituted under the Banking Companies (Acquisition &
Transfer of undertakings) Act, 1970 having its Head Office at _____ amongst
others a branch at (hereinafter referred to as "the Bank") has
agreed to give following guarantee in favour of the beneficiary for an amount
not exceeding Rs..... (Rupees only)
against any loss or damage caused to or suffered or would be caused to or
suffered by reason of any breach by the said Obligator(s) of any of the terms
and conditions contained in the said agreement.

1. We, the Bank to hereby undertake to pay the amount payable under this
guarantee without any demur merely on a demand from the beneficiary
stating that the amount claimed is due by way of loss or damage caused
to or would be caused to or suffered by reason or any breach of the
terms and conditions contained in the said agreement or by reason of the
obligator's failure to perform the said agreement. Any such demand in
writing made on the Bank shall be conclusive as regards the amount due
and payable by the Bank under the guarantee. However, our liability
under this guarantee shall be restricted to an amount not
exceeding Rs.....
2. We, the Bank further agree that the guarantee herein contained shall
remain in full force and effect during the period that would be taken for
the performance of the said agreement and that it shall continue to be
enforceable till all the dues of the beneficiary under or by virtue of the

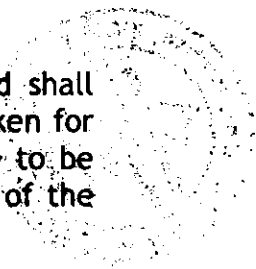
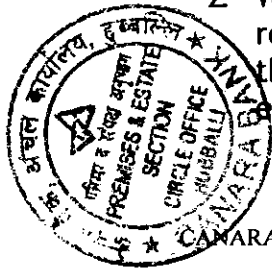

said agreement have been fully paid and its claims satisfied or till the beneficiary certifies that the terms and conditions of the said agreement have been fully discharged this guarantee. Unless a demand for claim under this guarantee is made on us in writing on or before we shall be discharged from all liabilities under this guarantee thereafter.

3. We, the Bank further agree that the beneficiary shall have the fullest liberty, without consent and without effecting in any manner or obligations hereunder, to extend time of performance the said obligator(s) from time to time or to postpone for any time any of the powers exercisable by the beneficiary against the said obligator(s) and to forbear or enforce any of the terms and conditions relating to the said agreement and we shall not be relieved of our liability by reason of any extension being granted to the said obligator(s) for any forbearance, act or omission on the part of the beneficiary or any indulgence by the beneficiary to the said obligator(s) or by any such matter or thing whatsoever which under the law relating to sureties would not for this provision have effect of so relieving us.
4. We, the Bank lastly undertake not to revoke this guarantee during its currency except with the previous consent of the beneficiary in writing.
5. Notwithstanding anything contained herein:
 - (i) Our liability under this Bank Guarantee shall not exceed Rs..... (Rupees only)
 - (ii) This Bank Guarantee is valid upto and
 - (iii) We are liable to pay the guaranteed amount or any part thereof under this Bank Guarantee only and only if you serve upon us a written claim or demand on or before..... (mention period of the guarantee as found under clause (ii) above plus claim period)

PLACE:

DATE:

SIGNATURE



ANNEXURE-16:

**INTEGRITY PACT FORMAT
PRE CONTRACT INTEGRITY PACT**

Between

This pre-bid contract Agreement (herein after called the Integrity Pact) is made on ____ day of the month 20____, between, **CANARA BANK** hereinafter referred to as "The Principal", a body corporate constituted under Banking Companies (Acquisition and transfer of undertakings), Act 1970 having its Head office at 112, J.C. Road, Bangalore 560 002, with branches spread over India and abroad (hereinafter referred to as BUYER which expression shall include its successors and assigns) acting through Shri _____, (Designation of the officer) representing _____, of the BUYER, of the FIRST PART

AND

M/s. _____ represented by Shri _____ Chief Executive Officer/Authorised Signatory (hereinafter called the "The Bidder/ Seller/ Contractor/ Service Provider", which expression shall mean and include, unless the context otherwise requires, his successors and permitted assigns), of the SECOND PART

The Principal intends to award, under laid down organizational procedures, contract/s for _____. The Principal values full compliance with all relevant laws of the land, rules, regulations, economic use of resources and of fairness/ transparency in its relations with its Bidder(s) and / or Contractor(s).

In order to achieve these goals, the Principal will appoint Independent External Monitors (IEMs) who will monitor the tender process and the execution of the contract for compliance with the principles mentioned above.

Section 1 - Commitments of the Principal

(1) The Principal commits itself to take all measures necessary to prevent corruption and to observe the following principles:-

- a) No employee of the Principal, personally or through family members, will in connection with the tender for, or the execution of a contract, demand, take a promise for or accept, for self or third person, any material or immaterial benefit which the person is not legally entitled to.
- b) The Principal will, during the tender process treat all Bidder(s) with equity and reason. The Principal will in particular, before and during the tender process, provide to all Bidder(s) the same information and will not provide to any Bidder(s) confidential/ additional information through which the Bidder(s) could obtain an advantage in relation to the tender process or the contract execution.

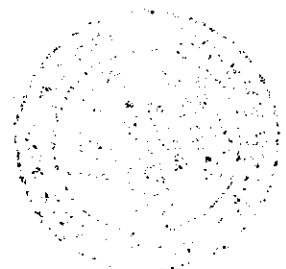

- c) The Principal will exclude from the process all known prejudiced persons.
- (2) If the Principal obtains information on the conduct of any of its employees which is a criminal offence under the IPC/PC Act, or if there be a substantive suspicion in this regard, the Principal will inform the Chief Vigilance Officer and in addition can initiate disciplinary actions.

Section 2 - Commitments of the Bidder(s)/ Contractor(s)

- (1) The Bidder(s)/ Contractor(s) commit themselves to take all measures necessary to prevent corruption. The Bidder(s)/ Contractor(s) commit themselves to observe the following principles during participation in the tender process and during the contract execution.
- a) The Bidder(s)/ Contractor(s) will not, directly or through any other person or firm, offer, promise or give to any of the Principal's employees involved in the tender process or the execution of the contract or to any third person any material or other benefit which he/ she is not legally entitled to, in order to obtain in exchange any advantage of any kind whatsoever during the tender process or during the execution of the contract.
- b) The Bidder(s)/ Contractor(s) will not enter with other Bidders into any undisclosed agreement or understanding, whether formal or informal. This applies in particular to prices, specifications, certifications, subsidiary contracts, submission or non-submission of bids or any other actions to restrict competitiveness or to introduce cartelisation in the bidding process.
- c) The Bidder(s)/ Contractor(s) will not commit any offence under the relevant IPC/PC Act; further the Bidder(s)/ Contractor(s) will not use improperly, for purposes of competition or personal gain, or pass on to others, any information or document provided by the Principal as part of the business relationship, regarding plans, technical proposals and business details, including information contained or transmitted electronically.
- d) The Bidder(s)/ Contractor(s) will, when presenting their bid, disclose any and all payments made, is committed to or intends to make to agents, brokers or any other intermediaries in connection with the award of the contract.
- e) Bidder(s)/Contractor(s) who have signed the Integrity Pact shall not approach the Courts while representing the matter to IEMs and shall wait for their decision in the matter.
- (2) The Bidder(s)/ Contractor(s) will not instigate third persons to commit offences outlined



above or be an accessory to such offences.

Section 3 - Disqualification from tender process and exclusion from future contracts

If the Bidder(s)/Contractor(s), before award or during execution has committed a transgression through a violation of Section 2, above or in any other form such as to put their reliability or credibility in question, the Principal is entitled to disqualify the Bidder(s)/Contractor(s) from the tender process or take action as below -

(1) Any breach of the provisions herein contained by the BIDDER/SELLER /CONTRACTOR/SERVICE PROVIDER or any one employed by it or acting on its behalf (whether with or without the knowledge of the BIDDER/SELLER/CONTRACTOR/SERVICE PROVIDER shall entitle the BUYER to take all or any one of the following actions, wherever required:-

- a) To immediately call off the pre-contract negotiations without assigning any reason or giving any compensation to the BIDDER/ SELLER/ CONTRACTOR/ SERVICE PROVIDER. However, the proceedings with the other BIDDER/ SELLER/ CONTRACTOR/ SERVICE PROVIDER(s) would continue.
- b) To forfeitfully or partially the Earnest Money Deposit (in pre-contract stage) and/or Security Deposit/Performance Bond (after the contract is signed), as decided by the BUYER and the BUYER shall not be required to assign any reason therefor.
- c) To immediately cancel the contract, if already signed, without giving any compensation to the BIDDER/ SELLER/ CONTRACTOR/ SERVICE PROVIDER.
- d) To recover all sums already paid by the BUYER, and in case of the Indian BIDDER/SELLER/CONTRACTOR/SERVICE PROVIDER with interest thereon at 2% higher than the prevailing Prime Lending Rate of (Name of the Bank/Financial Institution) while in case of a BIDDER/SELLER/CONTRACTOR/SERVICE PROVIDER from a country other than India with Interest thereon at 2% higher than the LIBOR. If any outstanding payment is due to the BIDDER/SELLER /CONTRACTOR from the BUYER in connection with any other contract such outstanding payment could also be utilized to recover the aforesaid sum and interest. The BUYER shall also be entitled to recover the replacement costs from BIDDER/SELLER/CONTRACTOR/SERVICE PROVIDER.
- e) To encash the advance bank guarantee and performance bond/ warranty bond, if furnished by the BIDDER/ SELLER/ CONTRACTOR/ SERVICE PROVIDER, in order to recover the payments, already made by the BUYER, along with interest.
- f) To cancel all or any other contracts with the BIDDER/ SELLER/ CONTRACTOR/ SERVICE PROVIDER and the BIDDER/ SELLER/ CONTRACTOR/ SERVICE PROVIDER shall be liable to pay compensation for any loss or damage to the BUYER resulting from such cancellation/rescission and the BUYER shall be entitled to deduct the amount so

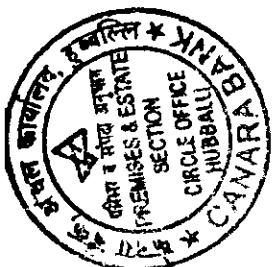

payable from the money(s) due to the BIDDER/ SELLER/ CONTRACTOR/ SERVICE PROVIDER.

- g) To debar the BIDDER/SELLER/CONTRACTOR/SERVICE PROVIDER from participating in future bidding processes of the BUYER for a minimum period of five years, which may be further extended at the discretion of the BUYER.
- h) To recover all sums paid in violation of this Pact by BIDDER/ SELLER/ CONTRACTOR/ SERVICEPROVIDER(s) to any middlemen or agent or broker with a view to securing the contract.
- i) In cases where irrevocable Letters of Credit have been received in respect of any contract signed by the BUYER with the BIDDER/ SELLER/ CONTRACTOR/ SERVICE PROVIDER, the same shall not be opened.
- j) Forfeiture of The Performance Bond in case of a decision by the BUYER to forfeit the same without assigning any reason for imposing sanction for violation of this Pact.
- k) The BIDDER/ SELLER/ CONTRACTOR/ SERVICE PROVIDER shall not lend to or borrow any money from or enter into any monetary dealings or transactions, directly or indirectly, with any employee of the BUYER, and if he does so, the BUYER shall be entitled forthwith to rescind the contract and all other contracts with the BIDDER/ SELLER/ CONTRACTOR/ SERVICE PROVIDER. The BIDDER/SELLER/ CONTRACTOR shall be liable to pay compensation for any loss or damage to the BUYER resulting from such rescission and the BUYER shall be entitled to deduct the amount so payable from the money(s) due to the BIDDER/ SELLER/ CONTRACTOR/ SERVICE PROVIDER.

(2) The BUYER will be entitled to take all or any of the actions mentioned as per above clause - 1 (i) to (xi) of this Pact, also in the event of commission by the BIDDER/ SELLER/ CONTRACTOR/ SERVICE PROVIDER or anyone employed by it or acting on its behalf (whether with or without the knowledge of the BIDDER), of an offence as defined In Chapter IX of the Indian Penal code, 1860 or Prevention of Corruption Act, 1988 or any other statute enacted for prevention of corruption.

(3) The decision of the BUYER to the effect that a breach of the provisions of this pact has been committed by the BIDDER/ SELLER/ CONTRACTOR shall be final and conclusive on the BIDDER/ SELLER / CONTRACTOR. However, the BIDDER/SELLER/CONTRACTOR/SERVICE can approach the Independent External Monitor (s) appointed for the purpose of this pact.

Section 4 - Compensation for Damages

- (1) If the Principal has disqualified the Bidder(s) from the tender process prior to the award according to Section 3, the Principal is entitled to demand and recover the damages equivalent to Earnest Money Deposit/ Bid Security.



- (2) If the Principal has terminated the contract according to Section 3, or if the Principal is entitled to terminate the contract according to Section 3, the Principal shall be entitled to demand and recover from the Contractor liquidated damages of the Contract value or the amount equivalent to Performance Bank Guarantee.

Section 5 - Previous Transgression

- (1) The Bidder declares that no previous transgressions occurred in the last three years with any other Company in any country conforming to the anti-corruption approach or with any Public Sector Enterprise in India that could justify his exclusion from the tender process.
- (2) If the Bidder makes incorrect statement on this subject, he can be disqualified from the tender process or action can be taken as mentioned in section 3, clause - 1a to 1k).

Section 6 - Equal Treatment of all Bidders/ Contractors/ Subcontractors

1. In case of Sub-contracting, the Principal Contractor shall take the responsibility of the adoption of Integrity Pact by the Sub-contractor.
2. The Principal will enter into agreements with identical conditions as this one with all Bidders and Contractors.
3. The Principal will disqualify from the tender process all bidders who do not sign this Pact or violate its provisions.

Section 7 - Criminal charges against violating Bidder(s)/ Contractor(s) / Subcontractor(s)

If the Principal obtains knowledge of conduct of a Bidder, Contractor or Subcontractor, or of an employee or a representative or an associate of a Bidder, Contractor or Subcontractor which constitutes corruption, or if the Principal has substantive suspicion in this regard, the Principal will inform the same to the Chief Vigilance Officer.

Section 8 - Independent External Monitor

1. The Principal appoints competent and credible Independent External Monitor for this Pact after approval by Central Vigilance Commission. The task of the Monitor is to review independently and objectively, whether and to what extent the parties comply with the obligations under this agreement.
2. The Monitor is not subject to instructions by the representatives of the parties and performs his/her functions neutrally and independently. The Monitor would have access to all Contract documents, whenever required. It will be obligatory for him/ her to treat the information and documents of the Bidders/Contractors as confidential. He/ she reports to the Managing Director, CANARA BANK.

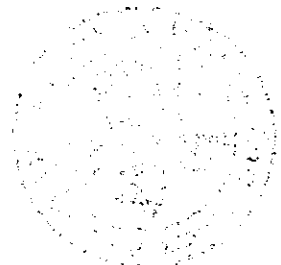

3. The Bidder(s)/Contractor(s) accepts that the Monitor has the right to access without restriction to all Project documentation of the Principal including that provided by the Contractor. The Contractor will also grant the Monitor, upon his/her request and demonstration of a valid interest, unrestricted and unconditional access to their project documentation. The same is applicable to Sub-contractors.
4. The Monitor is under contractual obligation to treat the information and documents of the Bidder(s)/ Contractor(s)/ Sub-contractor(s) with confidentiality. The Monitor has also signed declarations on 'Non-Disclosure of Confidential Information' and of 'Absence of Conflict of Interest'. In case of any conflict of interest arising at a later date, the IEM shall inform the Managing Director, CANARA BANK and recuse himself / herself from that case.
5. The Principal will provide to the Monitor sufficient information about all meetings among the parties related to the Project provided such meetings could have an impact on the contractual relations between the Principal and the Contractor. The parties offer to the Monitor the option to participate in such meetings.
6. As soon as the Monitor notices, or believes to notice, a violation of this agreement, he/she will so inform the Management of the Principal and request the Management to discontinue or take corrective action, or to take other relevant action. The monitor can in this regard submit non-binding recommendations. Beyond this, the Monitor has no right to demand from the parties that they act in a specific manner, refrain from action or tolerate action.
7. The Monitor will submit a written report to the Managing Director, CANARA BANK within 8 to 10 weeks from the date of reference or intimation to him by the Principal and, should the occasion arise, submit proposals for correcting problematic situations.
8. If the Monitor has reported to the Managing Director, CANARA BANK, a substantiated suspicion of an offence under relevant IPC/ PC Act, and the Managing Director, CANARA BANK has not, within the reasonable time taken visible action to proceed against such offence or reported it to the Chief Vigilance Officer, the Monitor may also transmit this information directly to the Central Vigilance Commissioner.
9. The word 'Monitor' would include both singular and plural.

Section 9 - Pact Duration

This Pact begins when both parties have legally signed it. It expires for the Contractor 12 months after the last payment under the contract, and for all other Bidders 6 months after the contract has been awarded. Any violation of the same would entail disqualification of the bidders and exclusion from future business dealings.



If any claim is made / lodged during this time, the same shall be binding and continue to be valid despite the lapse of this pact as specified above, unless it is discharged/ determined by the Managing Director, CANARA BANK.

Section 10 - Other provisions

1. This agreement is subject to Indian Law. Place of performance and jurisdiction is the Registered Office of the Principal, i.e. _____.
2. Changes and supplements as well as termination notices need to be made in writing. Side agreements have not been made.
3. If the Contractor is a partnership or a consortium, this agreement must be signed by all partners or consortium members.
4. Should one or several provisions of this agreement turn out to be invalid, the remainder of this agreement remains valid. In this case, the parties will strive to come to an agreement to their original intentions.
5. Issues like Warranty /Guarantee etc. shall be outside the purview of IEMs.

(For & On behalf of the Principal)
Seal)

(For & On behalf of Bidder/ Contractor) (Office
(Office Seal)

Place:

Date :

Witness 1:
(Name & Address)

Witness 2:
(Name & Address)



ANNEXURE-17:

Name of work:

Details on List of Retired Government / PSU / Bank employees, employed by the Tenderer:

NAME OF THE RETIRED OFFICIAL	DESIGNATION	NAME & ADDRESS OF THE PREVIOUS EMPLOYER

Name & Signature of Tenderer (with seal)

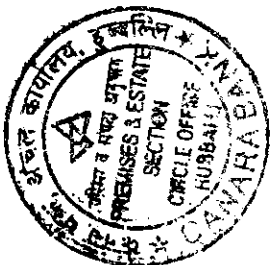

ANNEXURE-18:

Base Price of materials

Sl. No	Material	Basic Rate Including tax in Rs.
1.		
2.		
3.		



ANNEXURE-19:

INDEMNITY FORMAT

THIS DEED OF INDEMNITY executed at..... (Place) on this..... day of month of year two thousand and twenty (2020)

By..... (herein after called the contractor) duly represented by proprietor/one of its partners/director Sri

....., aged..... years, son of Sri.....

..... In favour of

Canara Bank, a body corporate constituted under the Banking companies (Acquisition and Transfer of undertakings) Act, 1970, having its Circle Office Office, at 112, J.C.Road, Bangalore - 560002 & represented by its Circle Office 52A, Shanbhag Building, Unkal Cross, Sai Nagar Road, Hubballi.

Whereas the contractor had applied for the tender

Whereas the tender submitted by the contractor for the above mentioned work was accepted by Canara Bank and the work of..... has been awarded in favor of the contractor vide Ref No

And whereas for undertaking the work awarded as per the above noted reference, the contractor has entered into contract with Canara Bank on

Now this Deed Witnessed that in pursuance of the aforesaid contract dated and in consideration of Canara Bank having agreed to make payment on the bills claimed by the contractor herein based on the works completed in respect of the above referred contract, the contractor hereby indemnifies and keep harmless Canara Bank & its Architect/consultant and its officials/staff from time to time and at all times against all actions, prosecutions proceedings, claims, suits, liabilities (including statutory liability), penalties, demands, charges, costs (including legal costs) and expenses, damages, losses and any other expenses which may be caused to or suffered by or made or taken against the Employer arising out of:

- i) The breach, default or non-performance of undertakings, warranties, covenants or obligations by the contractor, non-compliance of safety rules, regulations, instructions by the contractor and mishaps occurring at the site due to faulty work executed by the contractor.
- ii) Any contravention or Non compliance with any applicable laws, regulations, rules, statutory or legal requirements by the contractor.

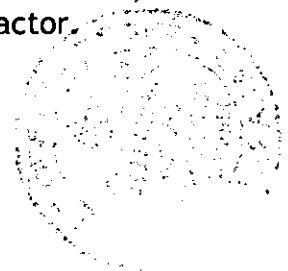

Further, the Contractor indemnifies to protect and save Canara Bank & its Architect/consultant and its officials / staff from against all claims, losses, costs, damages, expenses, action suits and other proceedings, resulting from infringement of any law pertaining to patent, trademarks, copyrights etc. or such other statutory infringements in respect of the services offered by the contractor.

All Indemnities shall survive notwithstanding expiry or termination of the contract and contractor shall continue to be liable under the indemnities.

There is no limit to claims made by the Employer/third parties in case of infringement of Intellectual property rights or for claims relating to the loss of damage to real property and tangible personal property and for bodily injury or death and in these cases the liability will be unlimited ”.

Signature of Contractor with Seal

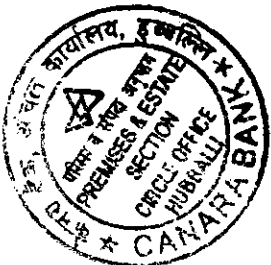

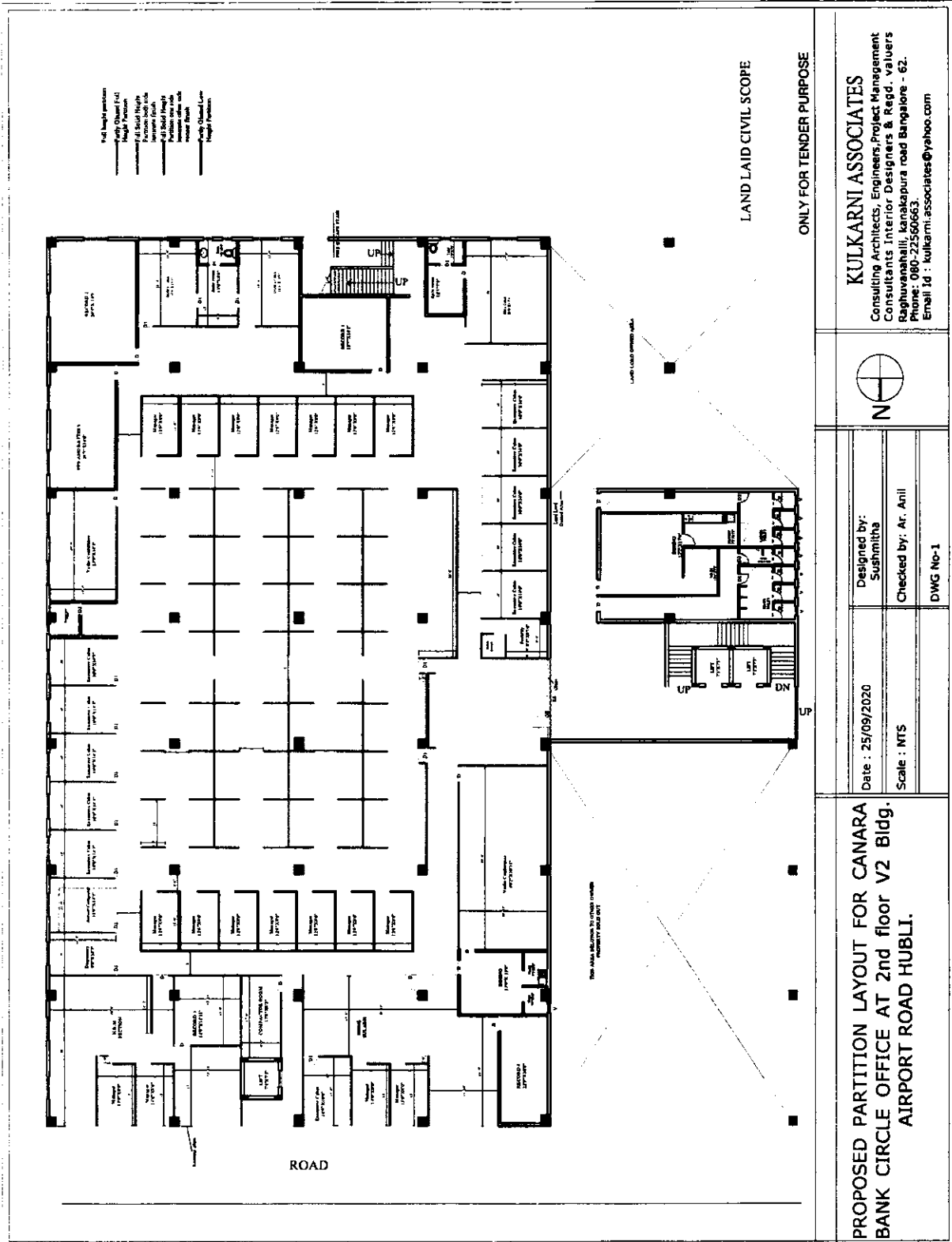

KULKARNI ASSOCIATES
 Consulting Architects, Engineers, Project Management
 Consultants Interior Designers & Regd. valuers
 Baghuvanshalli, Kanakapura road Bangalore - 62.
 Phone: 080-22560663
 Email id : kulkarni.associates@yahoo.com

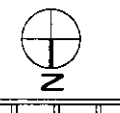

Date : 25/09/2020
 Scale : MTS
 Designed by: Sushmita
 Checked by: Ar. Anil
 DWG No-1

**PROPOSED PARTITION LAYOUT FOR CANARA
 BANK CIRCLE OFFICE AT 2nd floor V2 Bldg.
 AIRPORT ROAD HUBLI.**

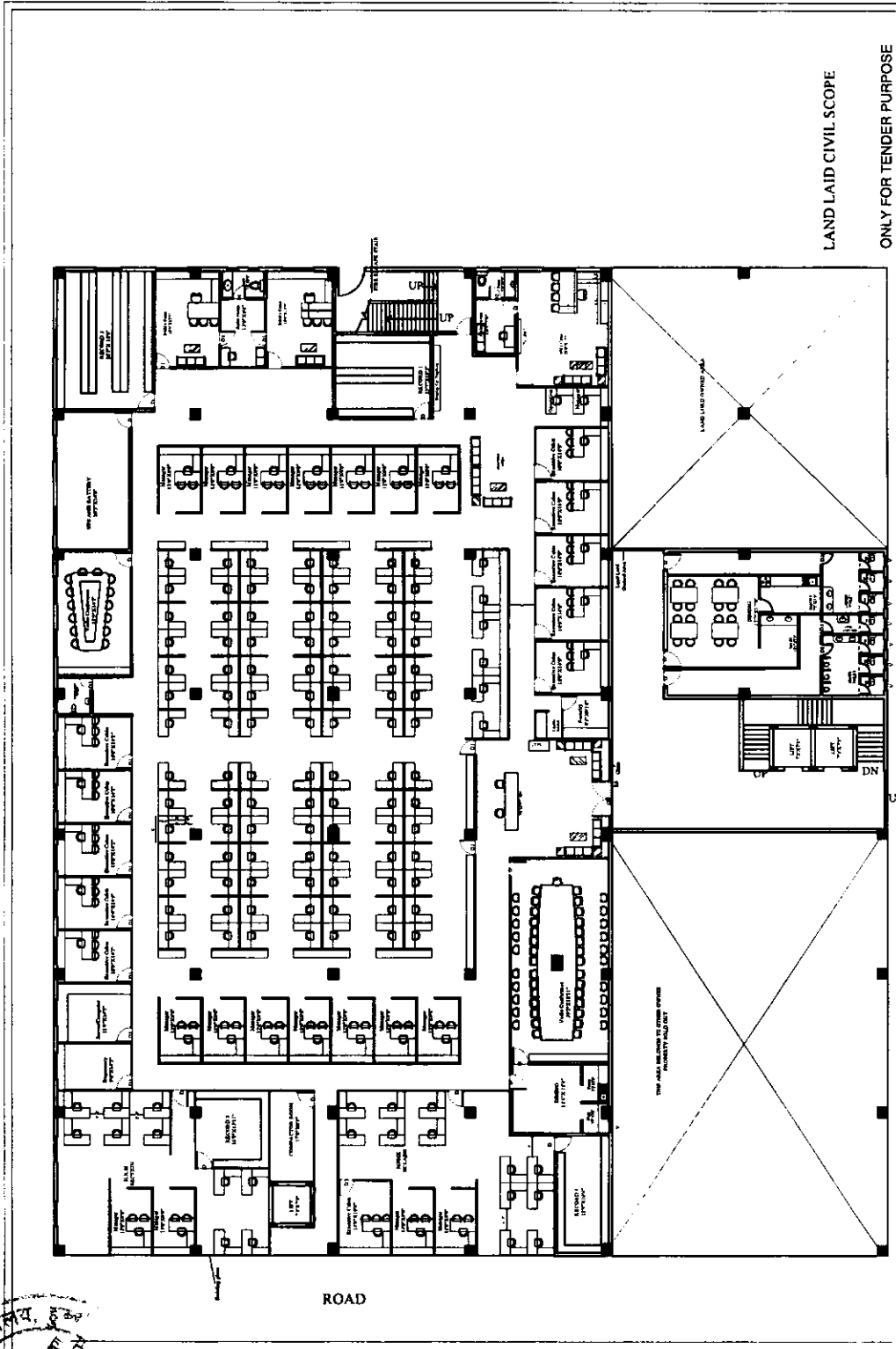
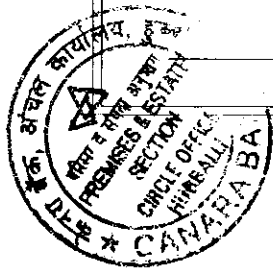

LAND LAID CIVIL SCOPE
ONLY FOR TENDER PURPOSE

PROPOSED FURNITURE LAYOUT FOR CANARA BANK CIRCLE OFFICE AT 2nd floor V2 Bldg. AIRPORT ROAD HUBLI.

KULKARNI ASSOCIATES
Consulting Architects, Engineers, Project Management
Consultants Interior, Designers & Regd. valuers
Raghuvanshalli, Kanakapura road Bangalore - 62.
Phone: 080-22560663
Email id : kulkarni.associates@yahoo.com

Designed by: **Susmitha**
Checked by: **Ar. Anil**
Date : 25/09/2020
Scale : NTS
DWG No-1



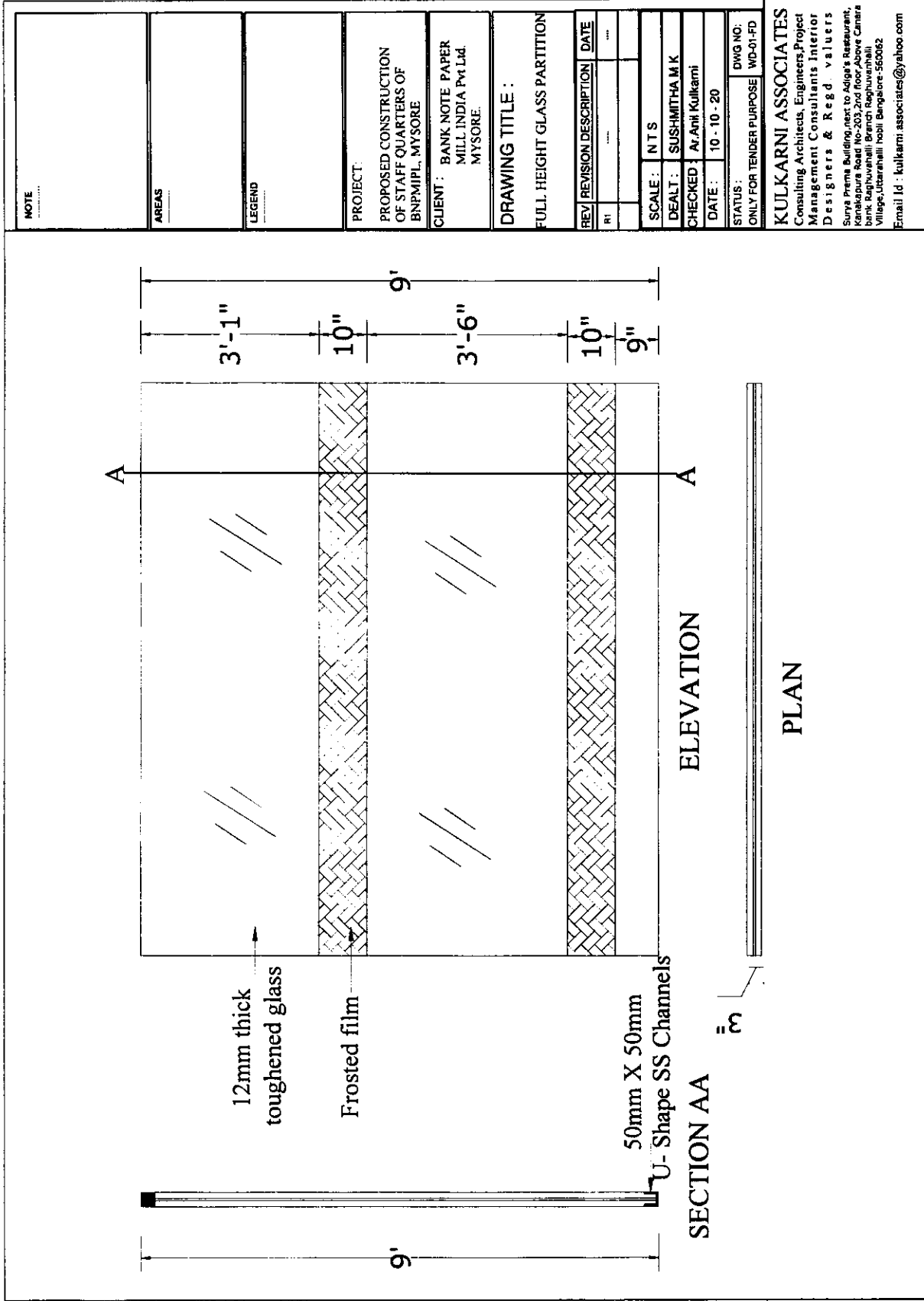

NOTE

AREAS

LEGEND

PROJECT:

PROPOSED CONSTRUCTION OF STAFF QUARTERS OF BNPMPIL, MYSORE

CLIENT: BANK NOTE PAPER MILL, INDIA PVT. LD. MYSORE.

DRAWING TITLE:

FULL HEIGHT GLASS PARTITION

REV	REVISION DESCRIPTION	DATE

SCALE: N T S

CHECKED: SUSHMITHA M K

DATE: 10 - 10 - 20

STATUS: DWG NO. ONLY FOR TENDER PURPOSE

WD-01-FD

KULKARNI ASSOCIATES
 Consulting Architects, Engineers, Project Management Consultants Interior Designers & Regd. valuers
 Surya Prama Building, next to Adiga's Restaurant, Kanakapura Road No-203, 2nd floor, Above Canara Bank, Raghuvahalli Branch, Raghuvahalli Village, Uttarahalli, Hobli, Bangalore-560062
 Email Id : kulkarni.associates@yahoo.com

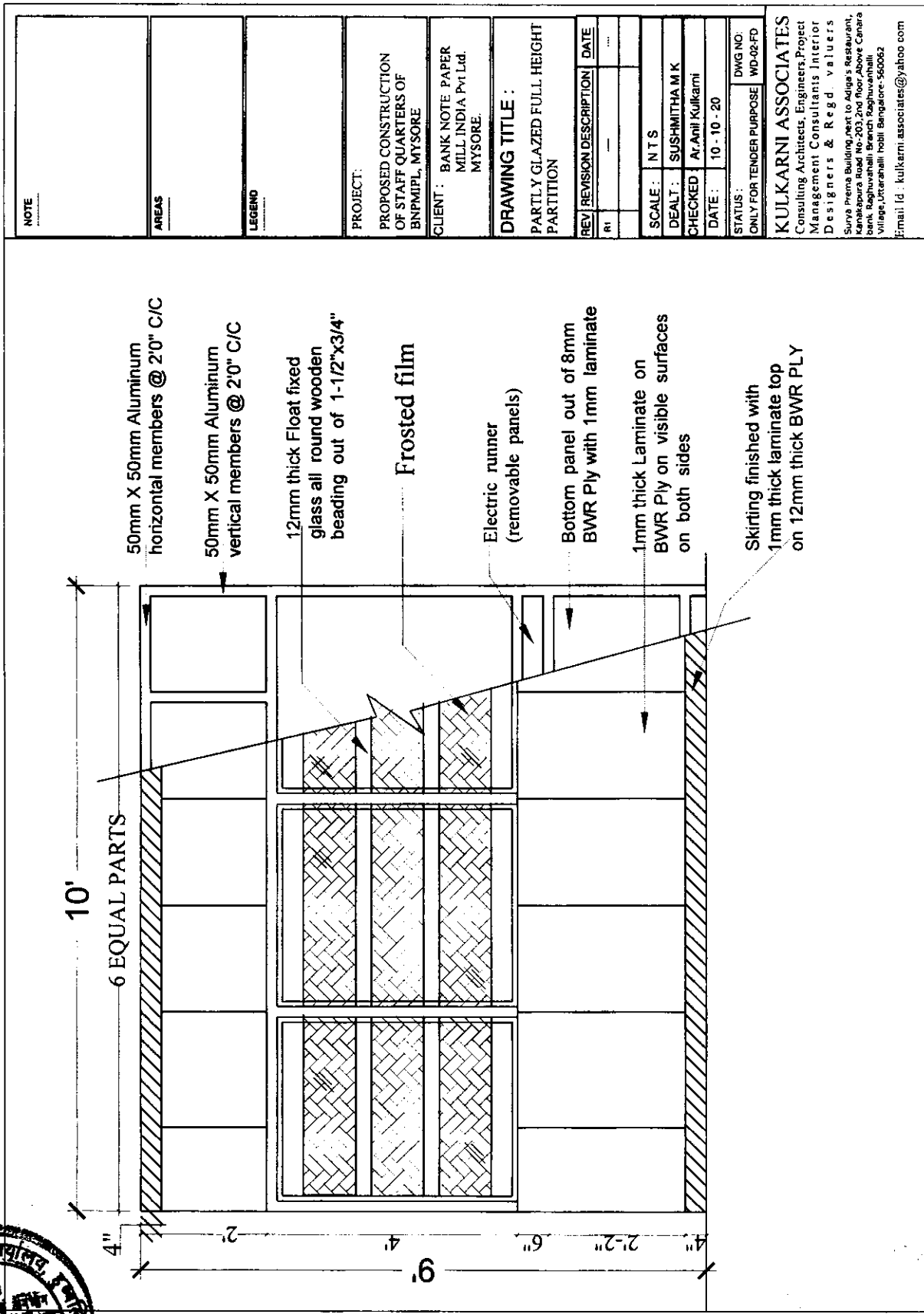
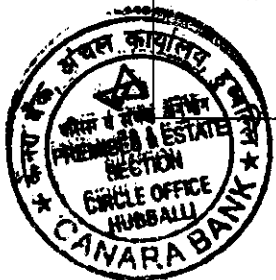

NOTE	
AREAS	
LEGEND	
PROJECT: PROPOSED CONSTRUCTION OF STAFF QUARTERS OF BNPML, MYSORE	
CLIENT: BANK NOTE PAPER MILL INDIA Pvt.Ltd. MYSORE.	
DRAWING TITLE: PARTLY GLAZED FULL HEIGHT PARTITION	
REV	REVISION DESCRIPTION DATE
R1	
SCALE:	NTS
DEALT:	SUSHMITHA M K
CHECKED:	Ar-Anil Kulkarni
DATE:	10 - 10 - 20
STATUS:	DWG NO: ONLY FOR TENDER PURPOSE WD-02-FD
KULKARNI ASSOCIATES Consulting Architects, Engineers, Project Management Consultants Interior Designers & Regd. valuers Surya Prerna Building, next to Adiga's restaurant, Kanakapura road, No-201, 2nd floor, Above Canara Bank, Kogalurmaini, Banneri nagruveennalli, Village, Uppanahalli, Bangalore-560062 Email Id : kulkarni.associates@yahoo.com	

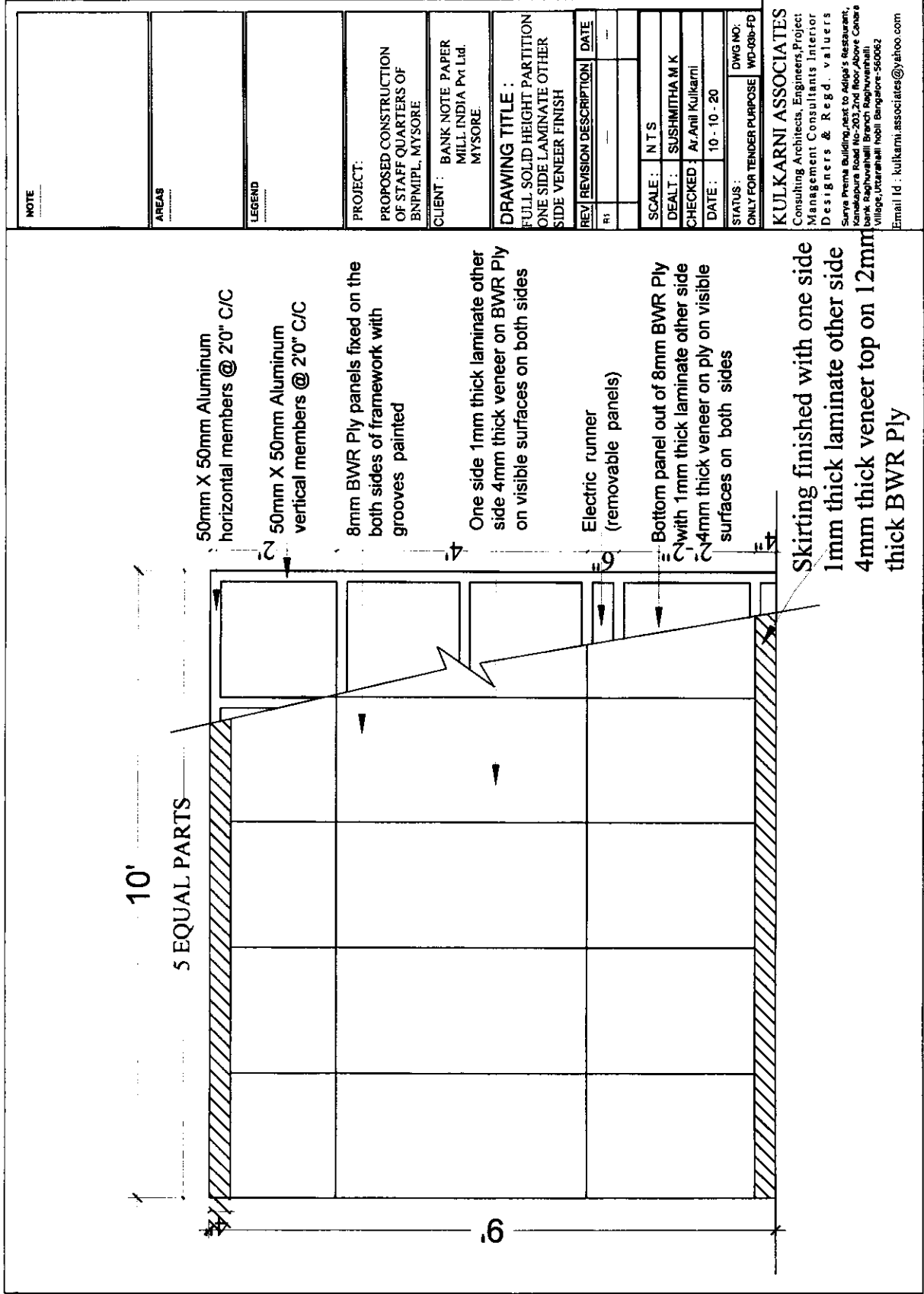

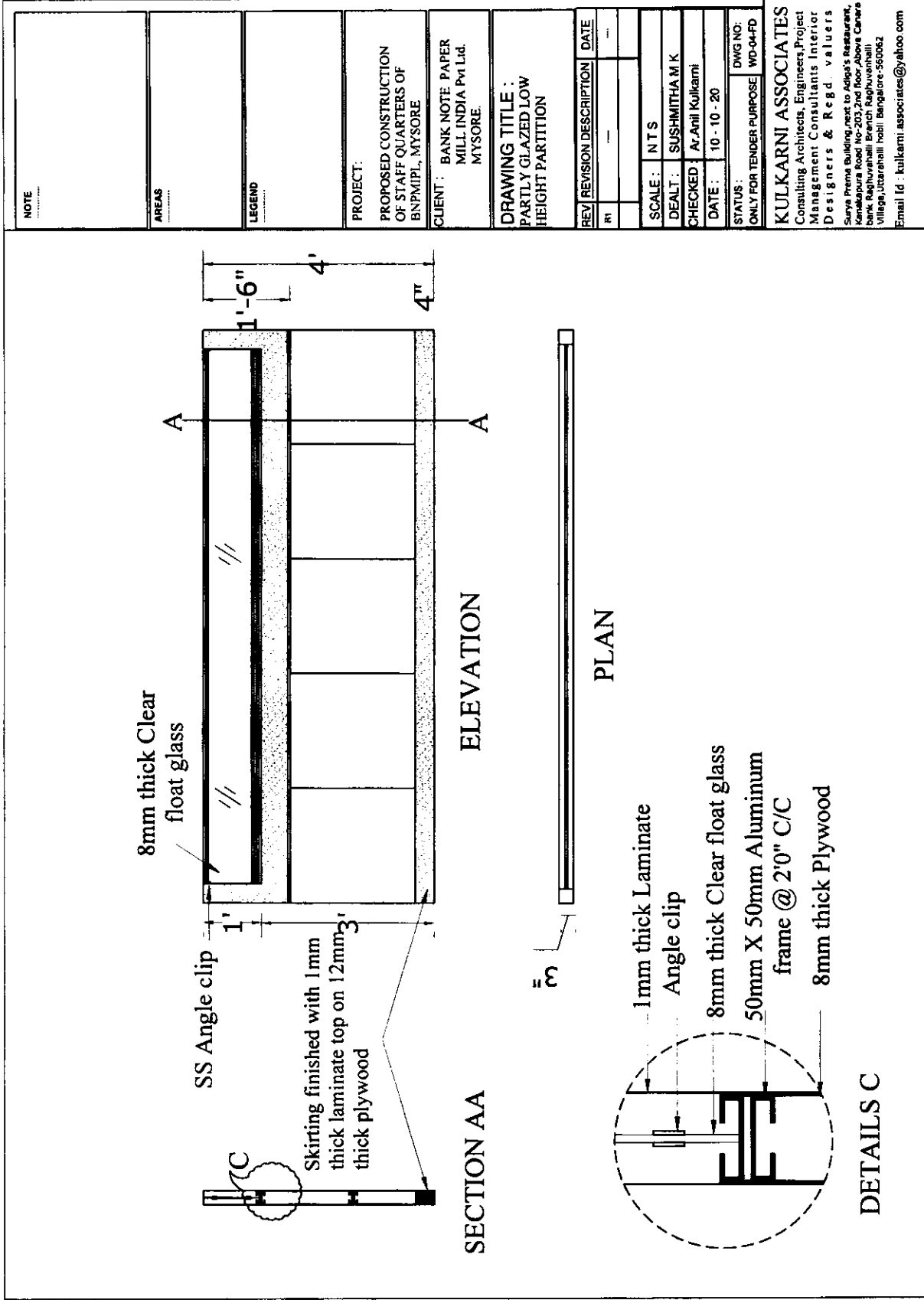

NOTE

AREAS

LEGEND

PROJECT:

PROPOSED CONSTRUCTION OF STAFF QUARTERS OF BNPMPIL, MYSORE.

CLIENT: BANK NOTE PAPER MILL INDIA Pvt Ltd. MYSORE.

DRAWING TITLE: PARTLY GLAZED LOW HEIGHT PARTITION

REV	REVISION DESCRIPTION	DATE

SCALE:	NTS
DEALT:	SUSHMITHA M K
CHECKED:	Ar. Anil Kulkarni
DATE:	10-10-20

STATUS:	DWG NO:
ONLY FOR TENDER PURPOSE	WD-04-FD

KULKARNI ASSOCIATES
 Consulting Architects, Engineers, Project Management Consultants Interior Designers & Regd. valuers
 Surya Prerna Building, next to Adiga's Restaurant, Kenelepur Road No-203, 2nd Floor, Above Canara Bank, Naghuvarhalli, Bengaluru, Karnataka
 Village, Uttarahalli, Hobli, Bangalore-560062
 Email Id: kulkarni.associates@yahoo.com

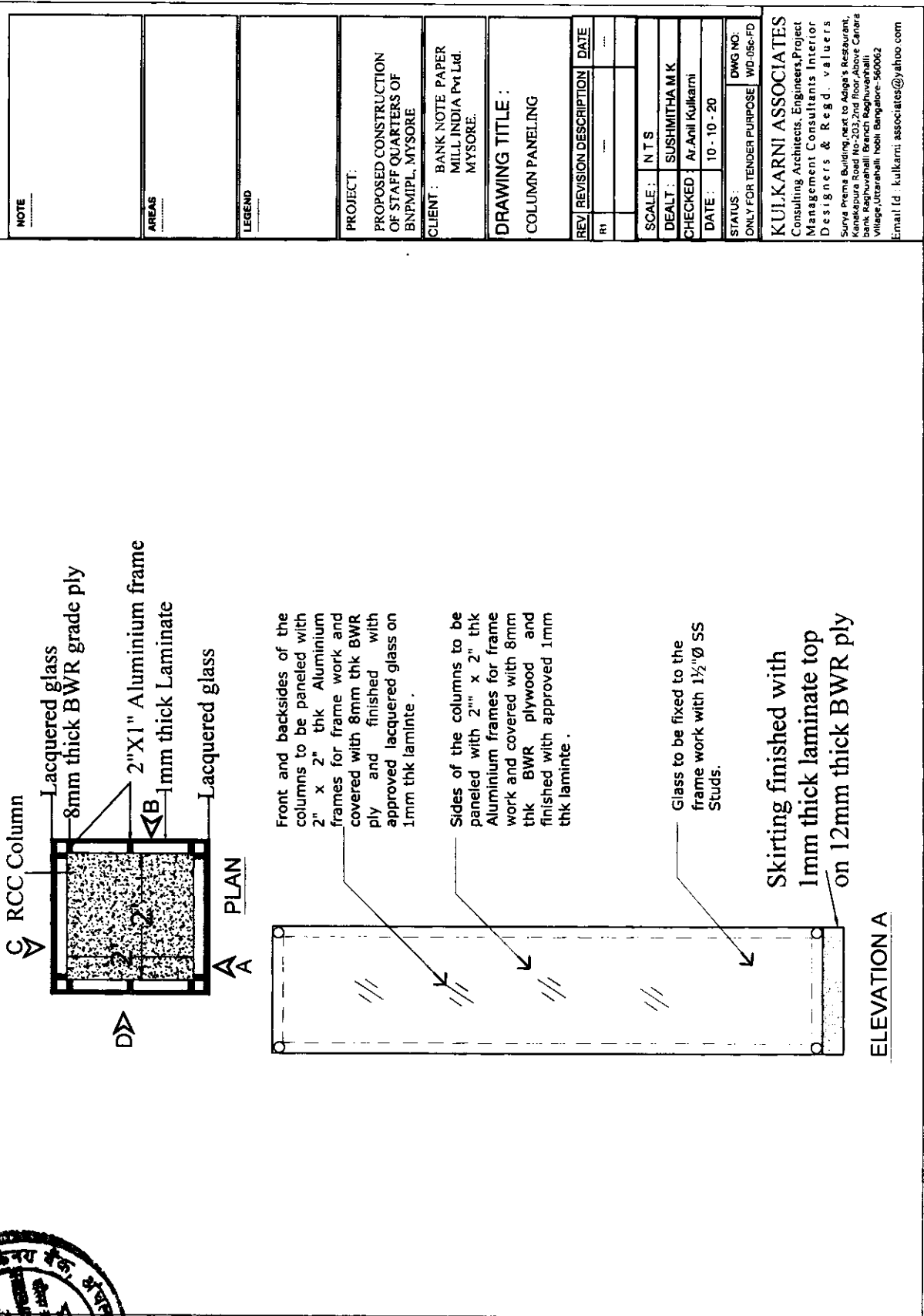

NOTE

AREAS

LEGEND

PROJECT:
 PROPOSED CONSTRUCTION
 OF STAFF QUARTERS OF
 BNPMTL, MYSORE

CLIENT : BANK NOTE PAPER
 MILL INDIA Pvt Ltd.
 MYSORE.

DRAWING TITLE :
 COLUMN PANELING

REV	REVISION DESCRIPTION	DATE

SCALE : N T S
DEALT : SUSHMITHA M K
CHECKED : Ar Anil Kulkarni
DATE : 10 - 10 - 20

STATUS : DWG NO: _____
 ONLY FOR TENDER PURPOSE WID-056-PD

KULKARNI ASSOCIATES
 Consulting Architects, Engineers, Project
 Management Consultants Interior
 Designers & Regd. valuers
 Surya Prerna Building next to Adage's Restaurant,
 Kankarapura Road No-203, 2nd floor, 4th Stage 4th
 block, Uttarahalli Branch Bangalore-560062
 Email Id : kulkarni_associates@yahoo.com

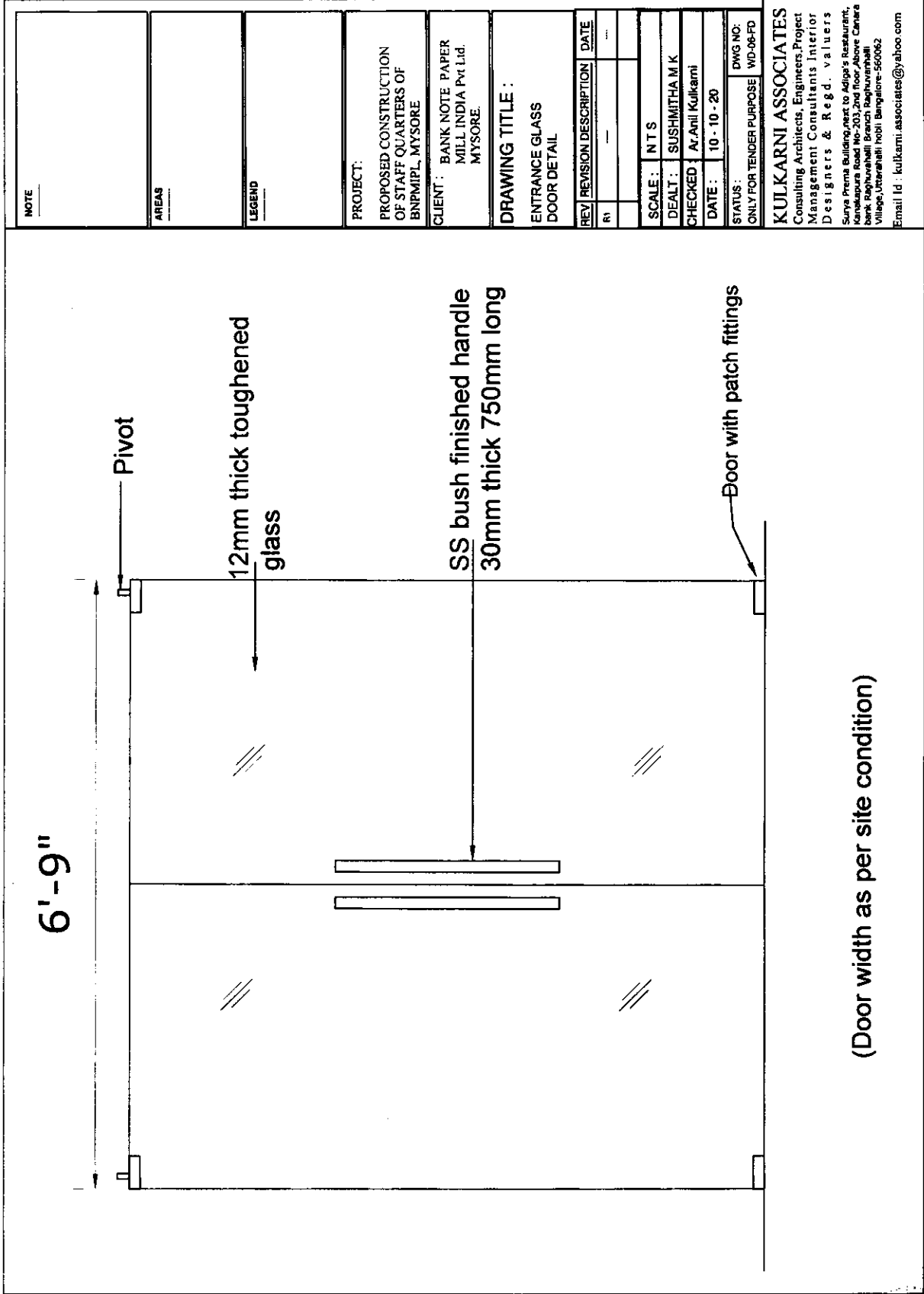

NOTE

AREAS

LEGEND

PROJECT:

PROPOSED CONSTRUCTION OF STAFF QUARTERS OF BNPMPIL, MYSORE.

CLIENT: BANK NOTE PAPER MILL INDIA Pvt Ltd. MYSORE.

DRAWING TITLE:

ENTRANCE GLASS DOOR DETAIL

REV	REVISION DESCRIPTION	DATE
R1		

SCALE: N T S

DEALT: SUSHMITHA M K

CHECKED: Ar Anil Kulkarni

DATE: 10 - 10 - 20

STATUS: DWG NO: ONLY FOR TENDER PURPOSE WD-06-FD

KULKARNI ASSOCIATES

Consulting Architects, Engineers, Project Management Consultants Interior Designers & Regd. valuers
 Surya Prama Building, Next to Adiga's Restaurant, Kanakapura Road No-203, 2nd Floor, Above Citinara Bank, Hogenahalli Branch, Bangalore-560082
 Email Id : kulkarni.associates@yahoo.com

(Door width as per site condition)

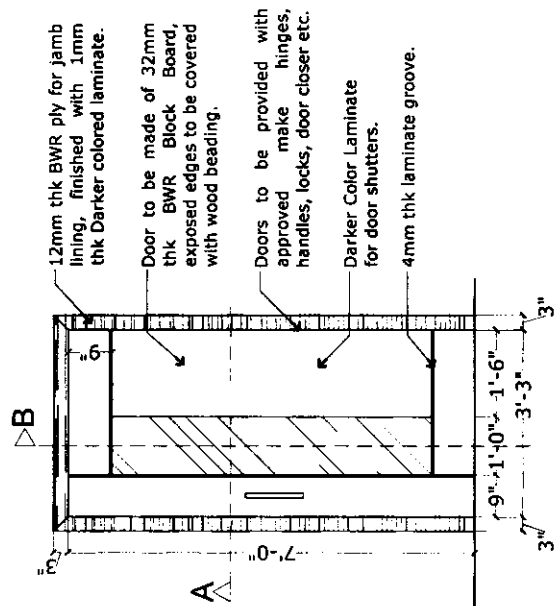

ELEVATION

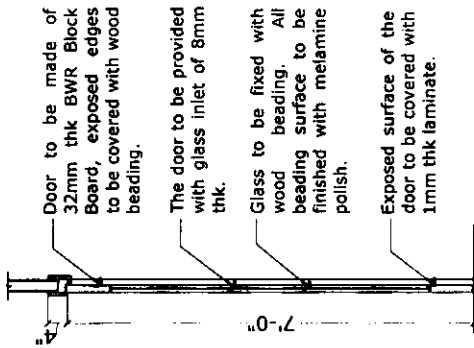

SECTION - BB

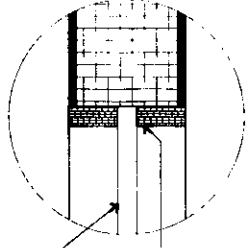

DETAIL - 2

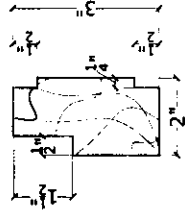

FRAME DETAILS

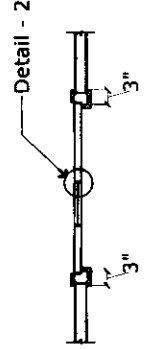

SECTION - AA

NOTE	
AREAS	
LEGEND	
PROJECT: PROPOSED CONSTRUCTION OF STAFF QUARTERS OF BNMPL, MYSORE	
CLIENT: BANK NOTE PAPER MILL INDIA Pvt Ltd. MYSORE.	
DRAWING TITLE: TYPICAL 3'-3" WIDE LAMINATE FINISHED VIEW paneled door.	
REV	REVISION DESCRIPTION DATE
SCALE: N T S	
DEALT: SUSHMITHA M K	
CHECKED: Ar/Anil Kulkarni	
DATE: 10 - 10 - 20	
STATUS:	DWG NO:
ONLY FOR TENDER PURPOSE	WD-07-FD
KULKARNI ASSOCIATES Consulting Architects, Engineers, Project Management Consultants Interior Designers & Regd valuers Surya Prerna Building, next to Adiga's Restaurant, Kanakapura Road No-203, 2nd floor, Above Canara bank Raghuvahalli Branch Raghuvahalli village, Uttarahalli hobli Bangalore-560022 Email Id : kulkarni.associates@yahoo.com	

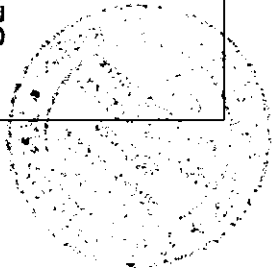

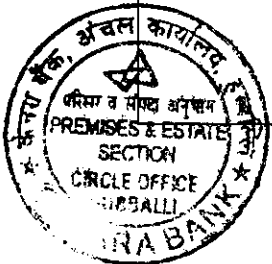

NOTE		
AREAS		
LEGEND		
PROJECT: PROPOSED CONSTRUCTION OF STAFF QUARTERS OF BNPMPL, MYSORE		
CLIENT: BANK NOTE PAPER MILL INDIA Pvt Ltd. MYSORE.		
DRAWING TITLE : DGM'S CABIN FRONT AND SIDE TABLE		
REV REVISION DESCRIPTION DATE		
R1		
SCALE: N T S		
DEALT: SUSHMITHA M K		
CHECKED: Ar. Anil Kulkarni		
DATE: 10 - 10 - 20		
STATUS: ONLY FOR TENDER PURPOSE DWG NO: WD-11b-FD		
KULKARNI ASSOCIATES Consulting Architects, Engineers, Project Management Consultants Interior Designers & Regd. values Surya Prerna Building, next to Adiga's Restaurant, Kanakapura Road No-203, 2nd floor, Above Centara Bank, Koginuvahalli Branch, Koginuvahalli, Village, Uttarahalli, Hobli Bangalore-560052 Email Id: kulkarni.associates@yahoo.com		

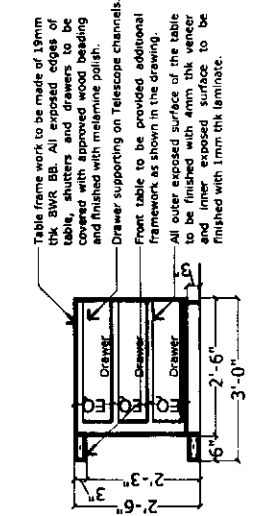
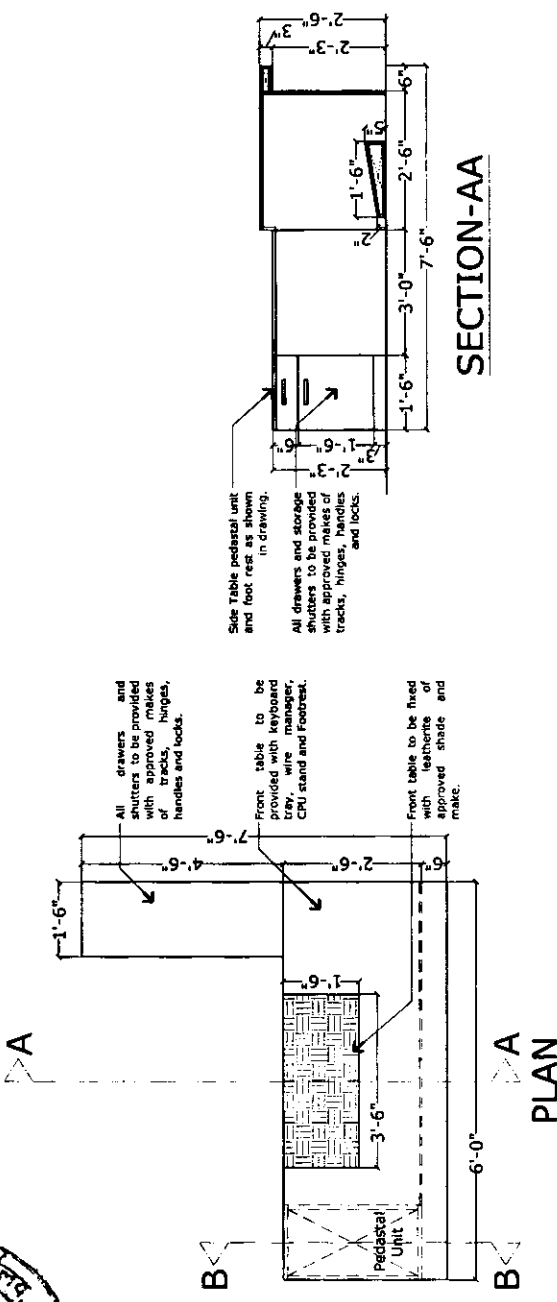

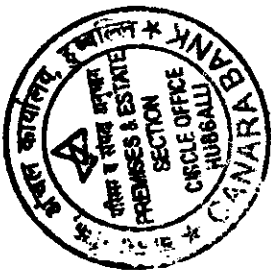

NOTE		
AREAS		
LEGEND		
PROJECT: PROPOSED CONSTRUCTION OF STAFF QUARTERS OF BNPMPL, MYSORE.		
CLIENT: BANK NOTE PAPER MILL INDIA Pvt Ltd. MYSORE.		
DRAWING TITLE: EXECUTIVE CABIN FRONT AND SIDE TABLE		
REV REVISION DESCRIPTION DATE		
01		
SCALE: N T S		
DEALT: SUSHMITHA M K		
CHECKED: Ar.Anil Kulkarni		
DATE: 10 - 10 - 20		
STATUS: ONLY FOR TENDER PURPOSE		
DWG NO: WD-12b-FD		

KULKARNI ASSOCIATES
Consulting Architects, Engineers, Project
Management Consultants Interior
Designers & Regd. valuers
Surya Prerna Building, next to Adige's Restaurant,
Kanakapura Road No-203, 2nd floor, Above Canara
Bank Raghuvanahalli Branch Raghuvanahalli
Village, Utcaranahalli hobli Bangalore-560062
Email Id : kulkarni.associates@yahoo.com

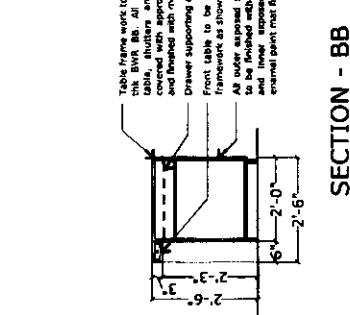
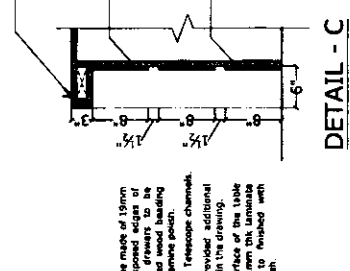
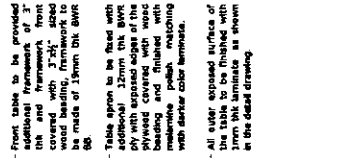
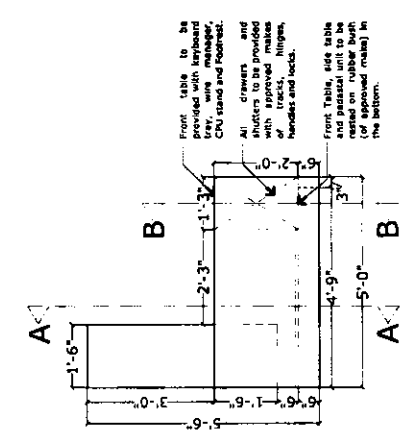
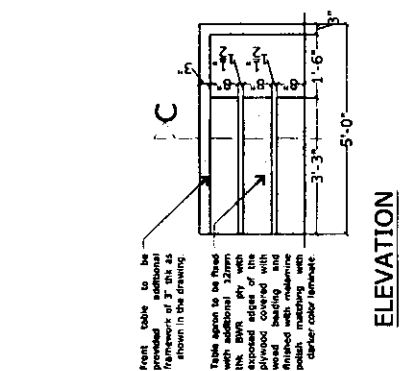
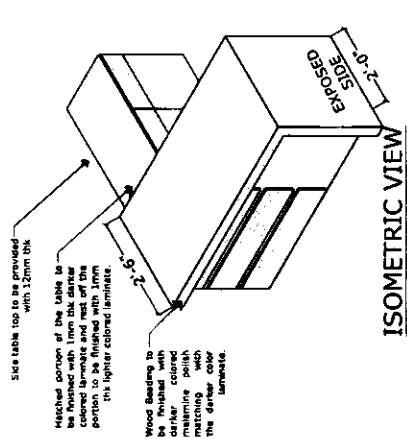

Front table to be provided additional framework of 32mm BWR ply with exposed edge of the wood beading, framework to be made of 12mm thick BWR ply.

Table apron to be fixed with additional framework of 32mm BWR ply with exposed edge of the wood beading and finished with melamine finish, matching with darker color laminate.

All outer exposed surface of the table to be finished with 12mm thick laminate as shown in the detail drawing.

Table frame work to be made of 12mm BWR ply with exposed edge of the wood beading and finished with melamine finish.

Drawer supporting on Telescopo channel.

Front table to be provided additional framework as shown in the drawing.

All outer exposed surface of the table to be finished with 12mm thick laminate as shown in the detail drawing.

Side table with 4 drawers as shown in drawing.

All drawers and storage shutters to be provided with approved makes of tracks, hinges, handles and locks.

Front table to be provided with keyboard tray, wire manager, CPU stand and footrest.

All drawers and shutters to be provided with approved makes hinges, handles and locks.

Front table side table and install unit to be fixed on rubber bush (of approved make) in the bottom.

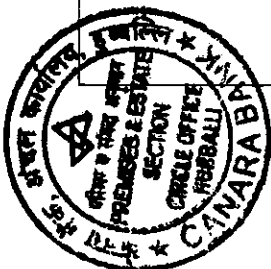

NOTE		
AREAS		
LEGEND		
PROJECT:	PROPOSED CONSTRUCTION OF STAFF QUARTERS OF BNPMPIL, MYSORE.	
CLIENT:	BANK NOTE PAPER MILL INDIA Pvt Ltd. MYSORE.	
DRAWING TITLE:	MANAGER CABIN FRONT AND SIDE TABLE	
REV	REVISION DESCRIPTION	DATE
R1		
SCALE:	N T S	
DEALT:	SUSHMITHA M K	
CHECKED	Ar Anil Kulkarni	
DATE:	10 - 10 - 20	
STATUS:	ONLY FOR TENDER PURPOSE	DWG NO: WD-12a-FD

KULKARNI ASSOCIATES
 Consulting Architects, Engineers, Project Management Consultants Interior Designers & Regd valuers
 Surya Prerna Building, next to Adiga's Restaurant, Kanakapura Road No-203, 2nd floor, Above Canara Bank, Rajgurunahalli Branch, Rajgurunahalli, Village, Utcarehalli hobli, Bangalore-560062
 Email Id: kulkarni.associates@yahoo.com

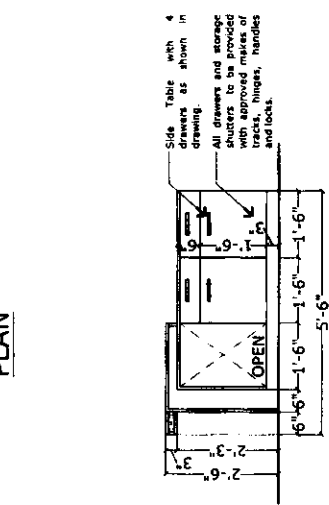
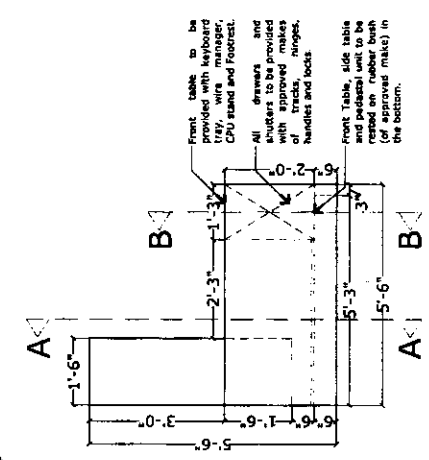
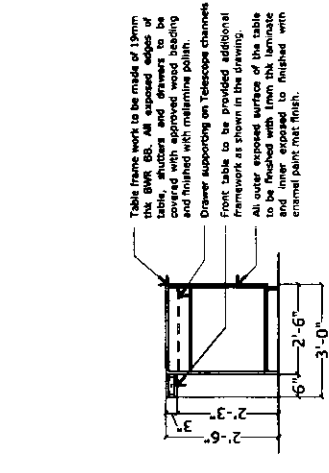
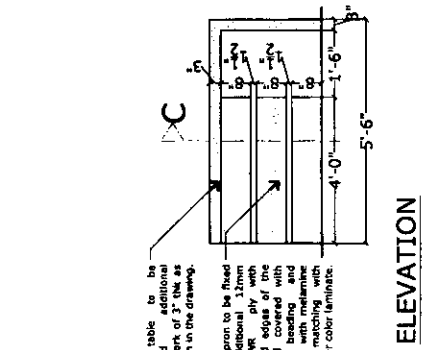
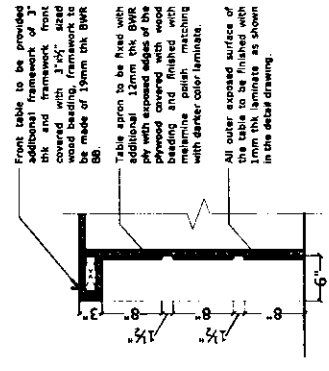
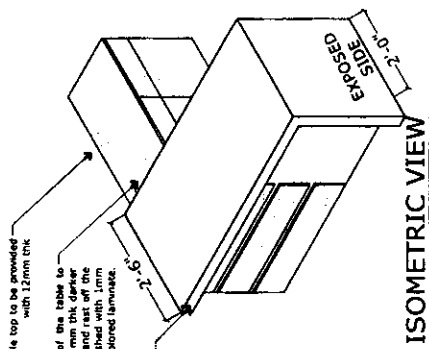

DETAIL - C

SECTION - BB

SECTION - AA



NOTE
AREAS
LEGEND
PROJECT: PROPOSED CONSTRUCTION OF STAFF QUARTERS OF BNPMPL, MYSORE
CLIENT : BANK NOTE PAPER MILL INDIA Pvt Ltd. MYSORE.
DRAWING TITLE : VIDEO CONFERENCE TABLE
REV. NO. / REVISION DESCRIPTION / DATE
SCALE : N T S
DEALT : SUSHMITHA M K
CHECKED : Ar-Anil Kulkarni
DATE : 10 - 10 - 20
STATUS : ONLY FOR TENDER PURPOSE
DWG NO : WD-049-FD
KULKARNI ASSOCIATES Consulting Architects, Engineers, Project Management Consultants Interior Designers & Regd. valuers Surya Prerna Building, next to Adiga's Restaurant, Kenechappura road No-203, 2nd floor, Above Chakra Bank, Rajahmundry, District Rajahmundry, Village, Udayavalli, Hobli, Bangalore-560062 Email Id : kulkarni.associates@yahoo.com

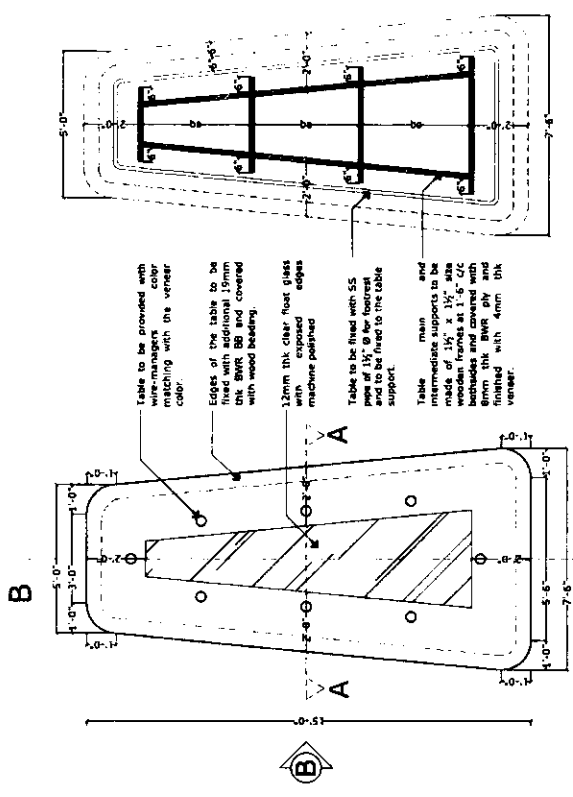

PLAN @ 2'-0" LEVEL

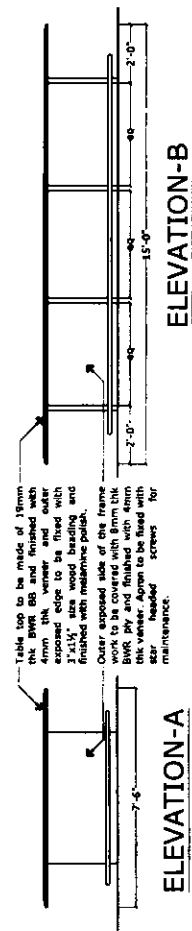

ELEVATION-B

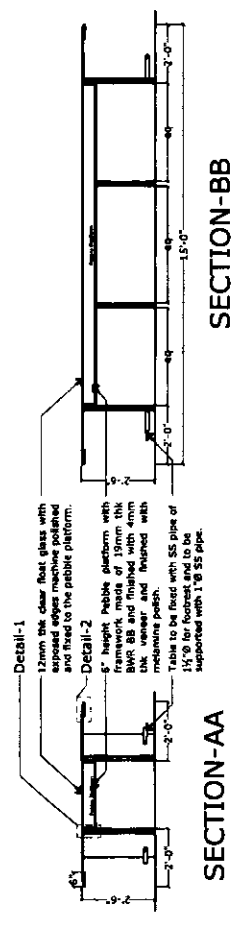

SECTION-BB

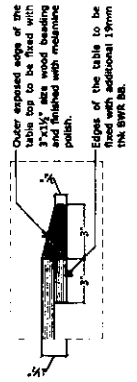
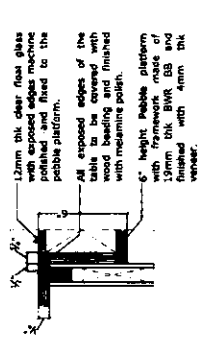

DETAIL-2



4'-6"

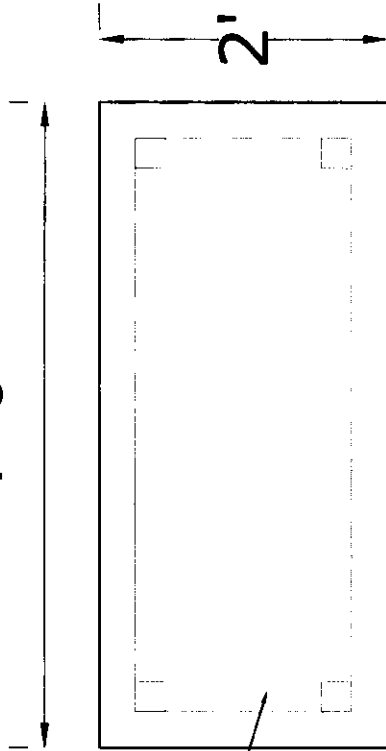

25mm thick block board finished with 1mm thick Dark laminate

PLAN

25mm thick block board finished with 1mm thick Dark laminate

3"
50mm X 50mm Beech wood frame work at top
0.8mm thick laminate for all internal surface
50mm X 50mm Beech wood vertically supporting legs

2'-6"

4"

ELEVATION

NOTE	
AREAS	
LEGEND	
PROJECT: PROPOSED CONSTRUCTION OF STAFF QUARTERS OF BNPMPIL, MYSORE	
CLIENT : BANK NOTE PAPER MILL INDIA Pvt Ltd. MYSORE.	
DRAWING TITLE : DINING TABLE DETAIL	
REV	REVISION DESCRIPTION DATE
SCALE :	N T S
DEALT :	SUSHMITHA M K
CHECKED :	Ar.Anil Kulkarni
DATE :	10 - 10 - 20
STATUS :	DWG NO.
ONLY FOR TENDER PURPOSE	
KULKARNI ASSOCIATES Consulting Architects, Engineers, Project Management Consultants Interior Designers & Regd. valuers Surya Prama Building, next to Adiga's Restaurant, Kanakapura Road No.203, 2nd floor, Above Canara Bank, Raghunahalli Branch Raghunahalli Village, Utharahalli, hobli Bangalore-560062 Email Id : kulkarni.associates@yahoo.com	

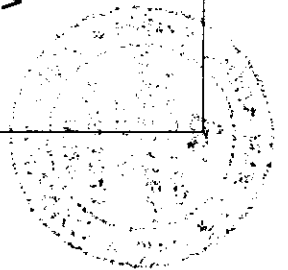

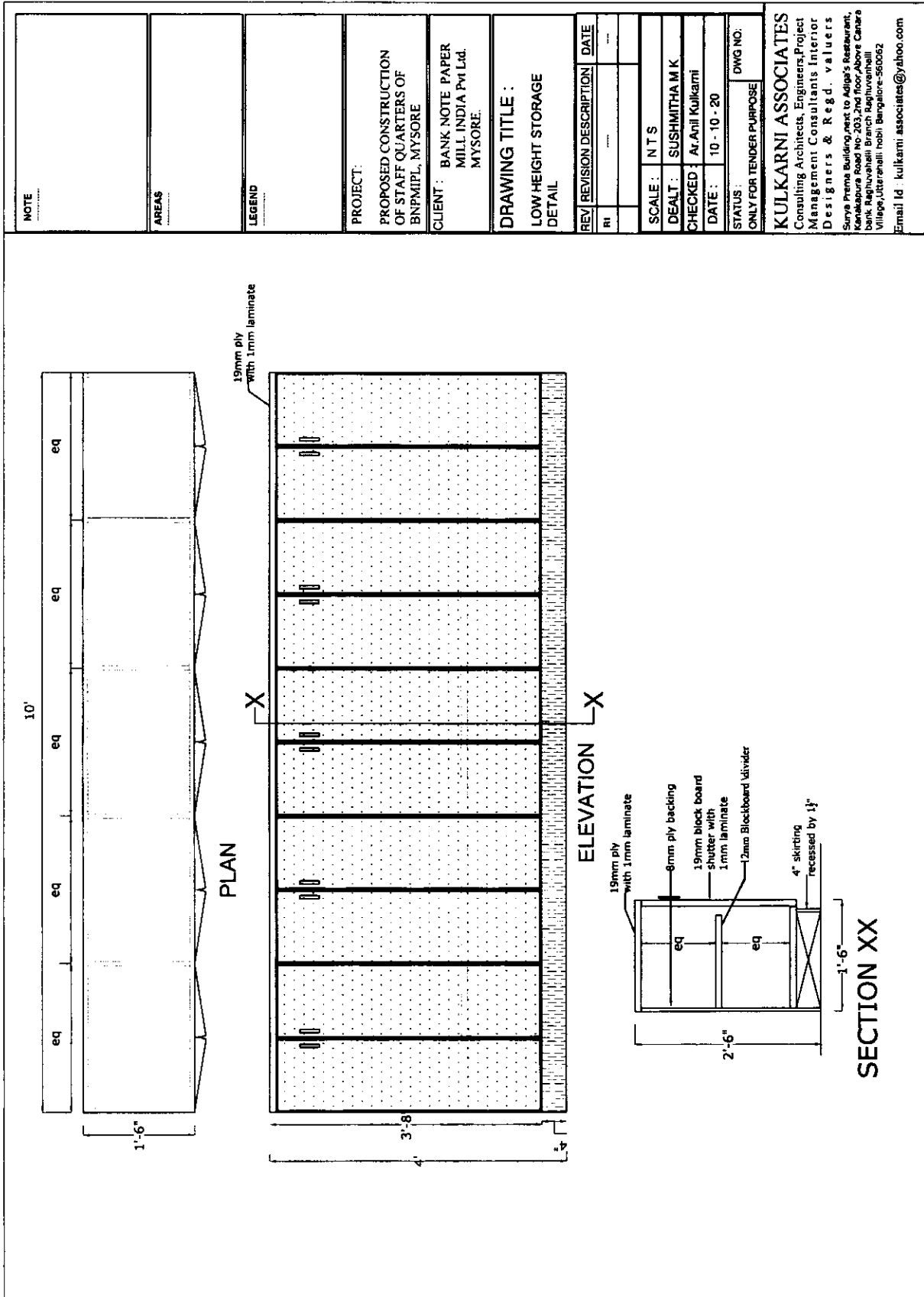
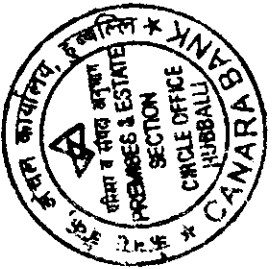

NOTE

AREAS

LEGEND

PROJECT:
PROPOSED CONSTRUCTION
OF STAFF QUARTERS OF
BNFMPL, MYSORE

CLIENT: BANK NOTE PAPER
MILL INDIA Pvt Ltd.
MYSORE.

DRAWING TITLE:
LOW HEIGHT STORAGE
DETAIL

REV	REVISION DESCRIPTION	DATE
RI		

SCALE: N T S
DEALT: SUSHMITHA M K

CHECKED: Ar. Anil Kulkarni

DATE: 10 - 10 - 20

STATUS: DWG NO.

ONLY FOR TENDER PURPOSE

KULKARNI ASSOCIATES
Consulting Architects, Engineers, Project
Management Consultants Interior
Designers & Regd. Valuers
Surya Prema Building, next to Adiga's Restaurant,
Kankapura Road No. 203, 2nd floor, Above Canara
bank, Rajahmundry Branch, Rajahmundry
Village, Uteranelli, hobi, Bangalore-560062
Email Id: kulkarni.associates@yahoo.com



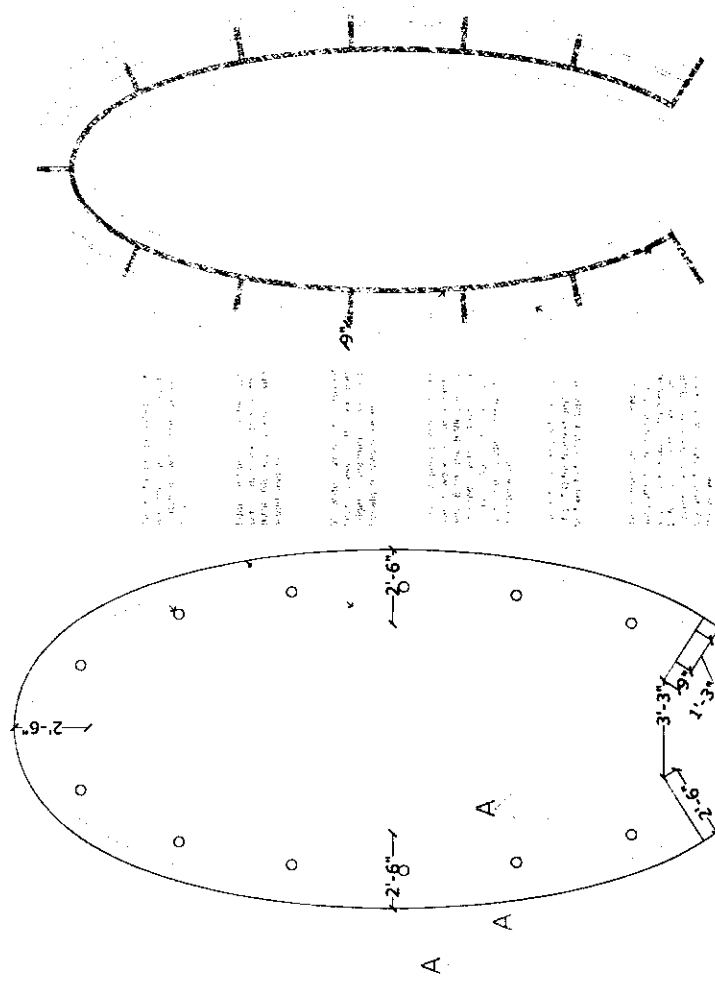
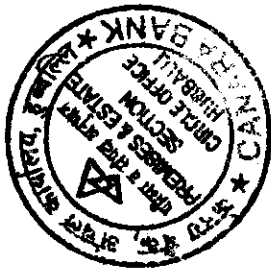

PLAN @ 2'-0" LEVEL

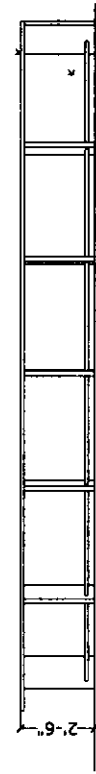

ELEVATION-A

Table top to be made of 1/2" thick 3/4" wide Lamin. Ply. Frontal edge glaze with resistant epoxy machine polished.

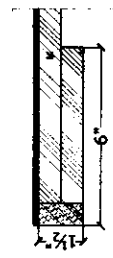

DETAIL-1

Table top to be made of 1/2" thick 3/4" wide Lamin. Ply. Frontal edge glaze with resistant epoxy machine polished.

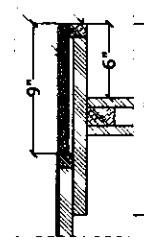

DETAIL-2

Table top to be made of 1/2" thick 3/4" wide Lamin. Ply. Frontal edge glaze with resistant epoxy machine polished.



SECTION-AA

Furniture Details For CANARA BANK CIRCLE OFFICE HUBLI.		CONFERENCE ROOM TABLE DETAILS		KULKARNI ASSOCIATES	
DWG TITLE	CONFERENCE ROOM TABLE DETAILS	DRAWING NO.	22/2020/2	CONSULTANT	PROJECT NO.
SCALE	1:1	DATE	22/06/20	CONSULTANT	PROJECT NO.

